



Institute for Catastrophic
Loss Reduction

Building resilient communities

Institut de Prévention
des Sinistres Catastrophiques

Construction de résilient communities

Designed for safer living®

Home builder's guide

Designed for safer living® is a program endorsed by Canada's insurers
to promote disaster-resilient homes.

June 2010



Designed ... for safer living®
Builder's Guide
2010 Edition

Legal Notice

© Copyright 2007 ICLR. All rights reserved. The ***Designed ... for safer living®*** registered service mark may not be used without the express written permission of ICLR. This Guide is the property of ICLR. ICLR further makes no representations or warranties, express or implied, as to the accuracy or timeliness of the information in this Guide, and it cannot be held responsible or liable for any errors or omissions contained therein or the results of relying on such information. Users are solely responsible for determining whether the information provided is suitable for their purposes and should rely on it at the users' sole risk. Users should obtain any additional information necessary to make an informed decision. ICLR assumes no responsibility or liability for any advice or services rendered by any builder, engineer, architect, inspector, manufacturer, or other industry participant as a result of using this Guide.

As a condition of using this Guide, the User agrees to indemnify ICLR from and against any and all actions, claims, losses, damages, liabilities and expenses (including reasonable attorneys' fees) arising from the User's use of this Guide, including, without limitation, any claims alleging facts that if true would constitute a breach by the User of these Terms and Conditions. If the User is dissatisfied with any information in this Guide or with any of these Terms and Conditions of Use, the User's sole and exclusive remedy is to discontinue using the Guide.

About the Institute for Catastrophic Loss Reduction

The Institute for Catastrophic Loss Reduction (ICLR), established in 1997, is a world-class centre for multidisciplinary disaster prevention research and communication. ICLR is an independent, not-for-profit research institute founded by the insurance industry and affiliated with the University of Western Ontario.

The Institute's mission is *to reduce the loss of life and property caused by severe weather and earthquakes through the identification and support of sustained actions that improve society's capacity to adapt to, anticipate, mitigate, withstand and recover from natural disasters.*

ICLR's mandate is to confront the alarming increase in disaster losses caused by natural disasters and to work to reduce disaster deaths, injuries and property damage. Disaster damage has been doubling every five to seven years since the 1960's, an alarming trend. The greatest tragedy is that many disaster losses are preventable. ICLR is committed to the development and communication of disaster prevention knowledge. For the individual homeowner, this translates into the identification of natural hazards that you and your home are vulnerable to. The Institute further informs individual homeowners what steps may be followed to better protect your family and your home.

TABLE OF CONTENTS

1 INTRODUCTION..... 1
2 THE COMPLIANCE PROCESS..... 3
3 BASEMENT FLOODING CRITERIA..... 4
4 SEISMIC CRITERIA..... 6
5 HURRICANE / TORNADO HIGH WIND CRITERIA..... 12
6 WILDFIRE REGION CRITERIA 31
7 SEVERE WINTER WEATHER CRITERIA..... 35
8 FLOOD REGION CRITERIA..... 36
9 HAIL REGION CRITERIA 39
10 OTHER PERILS..... 40
11 REFERENCES..... 43
12 CONTACT INFORMATION..... 45

APPENDIX 'A' **Seismic Zone Maps**
APPENDIX 'B' **Foundation reinforcing for seismic**

1 INTRODUCTION

Thank you for your interest in the Institute for Catastrophic Loss Reduction's **Designed ... for safer living®** homebuilding program. The program specifies construction and design guidelines to enable homes to increase their resistance to natural, catastrophe-level perils most likely to occur in the area. In addition, **Designed ... for safer living®** criteria exist for mitigation of damage caused by non-catastrophe-level perils, such as fire inside the home, burglary, water loss, and electrical surge. A builder is permitted to advertise a house as a **Designed ... for safer living®** home following satisfactory completion of construction, product verification, plus other documentation as specified by the program guidelines. Final designation as a **Designed ... for safer living®** home is issued by an authorized, independent inspector.

Briefly, the natural, catastrophe-level perils addressed by the **Designed ... for safer living®** program are:

Severe Wind: Practically every part of Canada is subject to some type of severe wind hazard that can readily exceed minimum requirements of even the best building codes. Types of severe winds include:

- ❑ **Hurricanes:** Catastrophic hurricanes can produce winds in excess of 150 mph (240 km/h). They are also responsible for a large portion of the cost per year damages to buildings due to wind. Hurricanes have also resulted in deaths and injuries to residents in some coastal areas. On the immediate coast, storm surge accounts for much of the damage. The **Designed ... for safer living®** program offers simple, yet effective solutions to reduce a building's vulnerability to both catastrophic and common hurricanes.
- ❑ **Tornadoes:** Tornadoes can occur in specific part of the country but are most common in areas of the country where design level wind speeds in the building code are at the lowest levels. In Canada, during an average year, approximately 80 tornadoes occur and, on average, cause two deaths and 20 injuries, plus tens of millions of dollars in property damage. These are the reported numbers, many more tornadoes strike unpopulated areas and go undetected. Many buildings would have survived with only moderate improvements as featured in the **Designed ... for safer living®** program.
- ❑ **Severe Thunderstorms:** Summer thunderstorms are a fairly common occurrence in most areas of Canada. Thunderstorms not only spawn tornadoes, but can also produce damaging winds of 112 mph (180 km/h) gust or more. Downbursts, which are also associated with thunderstorms, can produce tornado-like damage. Hail is also a hazard associated with thunderstorms and causes significant damage to the exteriors of thousands of buildings each year. The **Designed ... for safer living®** program provides improved resistance to these hazards associated with severe thunderstorms.

Earthquakes: Unlike wind, earthquakes come with no warning. There is little opportunity to take cover or vacate an unsafe building. In places like the West Coast, design level earthquakes may occur several times in a lifetime. In other parts of the country, moderate earthquakes occur with less frequency, but have happened in the not so distant past in several regions. Earthquakes are often the cause of significant damage and injury because it is "unexpected". Earthquake hazard zones in Canada are shown in a map attached to Appendix 'A' of the Guideline. The **Designed ... for safer living®** program addresses this significant and sometimes uncertain hazard with easily implemented solutions.

Floods: Buildings built in the inland or coastal 100-yr flood plain are in serious jeopardy of complete loss in the event of a flood. For this reason, significant measures are necessary to protect buildings from this potential hazard. Therefore, the **Designed ... for safer living®** program only applies to buildings that comply with the strictest condition in the *floodfringe zone* when building is permitted in these areas.

Wildfires: Every year, and even more so in recent years, wildfires have threatened and destroyed hundreds of buildings and lives. While some wildfires are naturally ignited from lightening or other causes, many are

the result of carelessness or arson. Simple site design, material usage and landscape features of the **Designed ... for safer living®** program can protect a home against this increasingly widespread hazard.

Severe Winter Weather: The majority of the regions in Canada are subjected to extreme weather pattern that causes severe damage to structure from heavy snow and cold. The **Designed ... for safer living®** program provides practical protection for homes from the damaging effects of this hazard.

Building Code Requirements

Building codes set a baseline of performance for many features within the home. While the **Designed ... for safer living®** program requires many items above and beyond building code requirements in terms of natural disaster resistance, it is still crucial that the home meet minimum requirements regarding structural system, electrical, mechanical, plumbing, weatherization, life and safety, and interior fire protection measures.

The National Building Code of Canada (NBCC) sets out the minimum requirements addressing safety, health accessibility and building protection. In addition, there are several other national codes such as the Plumbing Code, Electrical Code, and National Fire Code of Canada provides guidance and requirements for applicable systems in the building. Today most provinces and territories have passed legislation adopting either the national model building, fire and plumbing codes or variations that include provincial additions, exemptions, or amendments. Provinces and territories have also established systems of planning and development review that affect what can be built, generally with a large municipal role. Provincial and territorial laws for the environment, flood control, seismic hazard, occupational health and safety, etc. can also affect planning, construction and operation of buildings. In order to ensure that all **Designed ... for safer living®** homes receive an adequate minimum level of protection consistent with national and local building code requirements, homes built in some regions of the country must be inspected by a registered architect or professional engineer to certify that the home meets all applicable requirements of a specific model building code.

Statement of Land Use Policy

The **Designed ... for safer living®** program will be governed by local and municipal by-laws and zoning criteria concerning where it is deemed safe to build residential structures, except as follows: coastal regions subject to tidal surge and flooding, close proximity to known seismic fault lines, close proximity to major levees, and steep slopes potentially subject to either erosion or wildfire.

Natural Disasters – Adjusted for inflation 2006 (\$000)

1998	Quebec/Ontario	Icestorm	1,961,658
2005	Ontario	Wind/Rainstorm	509,813
2005	Alberta	Flooding	305,888
1996	Saguenay, Quebec	Flooding	254,230
1993	Winnipeg	Flooding	235,581
2003	British Columbia	Forest Fires	212,257
1996	Winnipeg	Flood/Hailstorm	180,187
2004	Edmonton	Hailstorm	172,976
2000	Ontario	Storm	146,520
1996	Calgary	Hailstorm	146,151
1999	Ontario	Snowstorm	140,951
2003	Nova Scotia	Hurricane	140,802

2 THE COMPLIANCE PROCESS

The process starts with a plan review. Following satisfactory completion of construction, inspection checklists, product verification and/or other documentation, final designation as a **Designed ... for safer living®** home is issued by ICLR.

Note that an ICLR Certified Inspector **must** verify that materials, installation, construction, and building techniques meet program criteria for the location.

Inspectors will meet with the builder prior to construction to discuss the appropriate criteria and review the building plans. The intent of this step is to set the stage for most of the field inspections. The inspector will review the drawings for all relevant criteria and communicate the requirements of the program to the builder. In order to effectively complete the drawing review, the builder will need to supply the following information:

- Architectural drawings showing floor plans and elevations.
- Window/Door schedule.
- Structural drawings (if applicable).
- Base Flood Elevation (if applicable).
- Truss drawings from the truss manufacturer.
- Documentation on wall and roof sheathing, fastening schedules and roof covering materials used.

The inspector will visit the site approximately four (4) times during the construction of the building to verify compliance to the **Designed ... for safer living®** standards. After the last inspection, the builder or homebuyer will receive a certificate from ICLR designating compliance with the **Designed ... for safer living®** program. (Figure 1-1).

For additional details, please contact the ICLR program staff listed in Section 17.

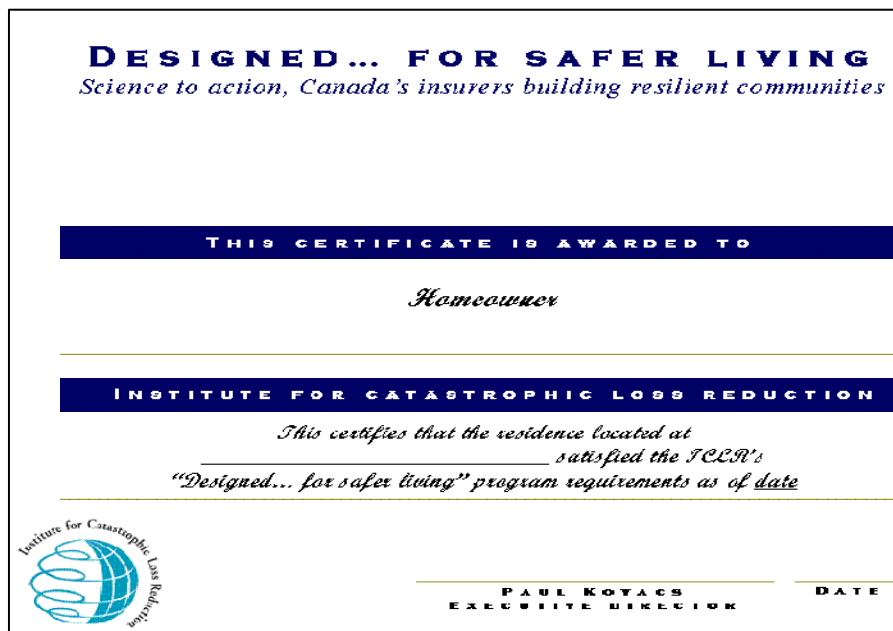

Figure 1-1: Sample of **Designed ... for safer living®** Certificate

3 BASEMENT FLOODING CRITERIA

Basement Flooding caused by Urban Flooding

During heavy rainfall or snowmelt events, almost any home can be vulnerable to flooding including those located outside of the floodplain (see *Flood Region Criteria* section). Basement flooding generally has three causes: Overland flooding, infiltration flooding and sewer backup.

- Overland flooding can occur during extreme rainfall or snowmelt events, where stormwater flows onto private property. This water can enter homes through basement windows, doors, vents and other openings including reverse sloped driveways.
- Infiltration flooding occurs when the soil around the home's foundation becomes saturated with groundwater, or when the groundwater level exceeds the height of the basement floor. Groundwater can then infiltrate into the basement through cracks in foundation walls and basement floors.
- Sewer backup originates from the municipal stormwater or sanitary sewer system and can occur when underground sewer systems surcharge due to high water volumes in the system. When underground sewer systems surcharge, sewage can backup into home sewer connections, which can result in water and sewage backing up into the home through plumbing fixtures or backing up into the foundation drain causing possible structural damage to the home.

To reduce the risk of sewer backup, ensure that the home is isolated from the municipal sewer system, to the extent possible. This may include:

- Severance of sanitary sewer connections, to the extent possible, including:
 - o Installation of an open-port, mainline sanitary sewer backwater valve on the main sanitary sewer lateral. The installation must meet manufacturer's and municipal guidance for such devices, including proper placement of the valve on the sanitary lateral. Installation of the backwater valve must also meet national, provincial and local building code requirements. Installation of a backwater valve will require proper disconnection of weeping tiles and eavestrough downspouts from the home's sanitary sewer connection. Inspect and confirm that the backwater valve is in good working order on an annual basis;
- Severance of storm sewer connections, to the extent possible. This includes:
 - o Drainage of weeping tiles into a sump pit, and then using a sump pump to pump foundation drain discharge to the surface of the lot. This practice must meet municipal guidelines for pumping foundation drainage to the surface of the lot, where appropriate, including proper extensions to keep discharges away from the foundation. Inspect and clean pump and pit on annual basis, and;
 - o Disconnection of eavestrough downspouts, including proper extensions and splash pads extended away from the foundation walls.

To reduce the risk of overland flooding and infiltration flooding, the following actions may be taken:

- Proper lot grading:
 - o The lot must be graded to meet municipal lot grading guidelines including placement of appropriate swales;
 - o Installation of window wells for windows close to ground level where appropriate, and installation of covers on the window wells;
 - o Proper backfilling, including capping backfill area with a soil that has a low porosity, for example, clay;
- Disconnection of eavestrough downspouts, including proper extensions and splash pads extended away from the foundation walls. Water may also be directed into a rain barrel, provided that proper overflow extensions are provided with the rain barrel and the rain barrel is installed based on manufacturer's instructions;
- Do not install reverse sloped driveways, and;

- Reduce the amount of hard surfaces on a lot, to the extent possible, and include "soft" landscaping where appropriate, including vegetated areas and gardens.

Mandatory Actions to Reduce Basement Flood Risk:

- In many cases, municipal governments have carried out detailed engineering studies on the causes of urban flooding in their jurisdiction. Investigate whether such studies have been conducted, and integrate the findings into the home/lot design. Also, ensure that any guidance and regulations on reduction of basement flooding available from the municipal government are integrated into the home/lot design;
- Do not install reverse sloped driveways;
- Lot grading must meet municipal guidelines, including proper backfilling;
- Drainage of eavestrough downspouts and foundation drains to the surface of the lot, based on municipal guidelines;
- Proper disconnection of the foundation drain from the home's sewer connections, and installation of a sump-pit and sump-pump to discharge water to the lot's surface, based on municipal guidelines. A backup sump-pump that can run when the main pump fails or during a blackout should also be installed, and;
- Ensure home is isolated from the municipal sewer system(s), to the extent possible, where the municipality permits.

Highly recommended, but not mandatory:

- Installation of an open-port backwater valve on the sanitary sewer lateral;
- Reduce the amount of hard surfaces on the lot;
- Foundation walls waterproofing membrane;
- Installation of warning devices such as alarms to detect high water level in the sump-pit or malfunction of the sump-pump, and;
- Selection of moisture resistant flooring and wall finishes in the basement.

4 SEISMIC CRITERIA

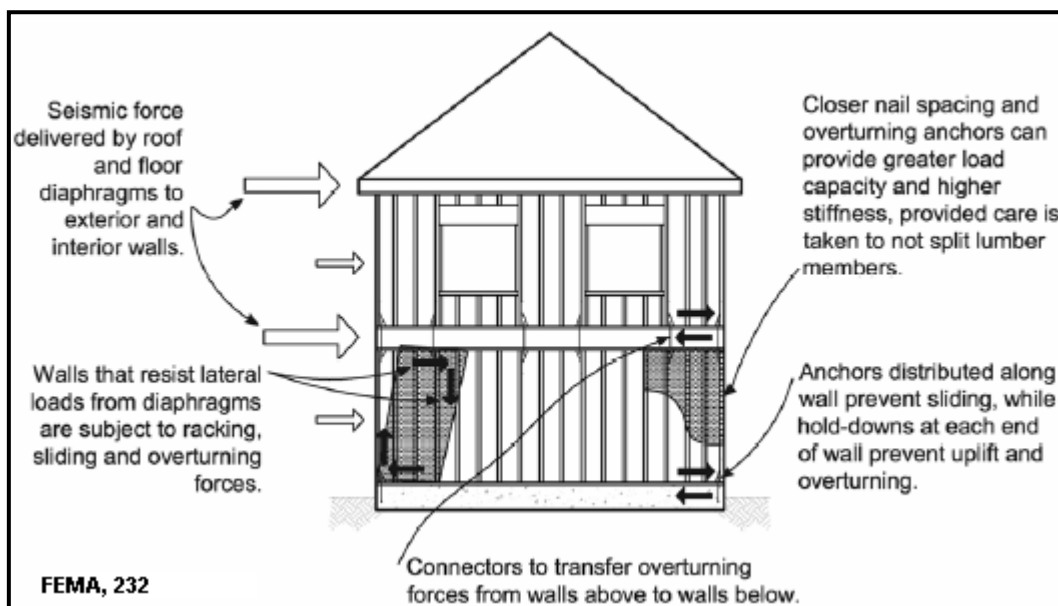

Introduction

Homes are engineered for the loads placed on them by building materials and environmental forces. The seismic forces are rarely experienced, but can be a threat to structural integrity and the survival of the equipment and contents in the home. Seismic forces act on all building components, unlike wind loads that primarily impact on the external envelop. Nevertheless, many design details relating to inter-storey connections and foundation anchoring, enhance a building's capacity to resist earthquake and wind load, and these are covered in Section 3 on Wind Criteria and not repeated here. The seismic criteria of the **Designed ... for safer living®** program are selected to produce a home, which resists and sometimes dissipates seismic forces in order to minimize damage to the building structure and systems.

Advanced Engineering Design

Most single family and small multi-family dwellings are built under Part 9 of the provincial version of the National Building Code of Canada (NBCC). Seismic criteria are incorporated into the various structural requirements. However, for homes with more complex shapes or structural elements, which may affect building performance under seismic loading, the builder is directed from Part 9 to Part 4 of the Code.

It is in Part 4, that seismic force calculations for more complex structures are located. While the **Designed ... for safer living®** home may not always require significant additional structural strengthening following Part 4 analysis, it provides the basis for producing a higher performance home.

Part 4 lateral force calculations include an Importance Factor (I_E) multiplier, which for a standard home is 1.0. **Designed ... for safer living®** homes have an increased Importance Factor of 1.2, which compares with the Code designations of 1.3 for schools and 1.5 for hospitals and other strategic facilities. These higher classifications produce a building, which is designed to have reduced risk of damage and the ability to remain occupied during period following most earthquakes. Some building elements may be strengthened, connectors somewhat more numerous and anchors with occasionally deeper embedments. The use of Part 4 allows for a wide variety of home designs, while producing enhanced seismic performance.

An Engineer on the Team

Each home construction project under the **Designed ... for safer living®** program has a Structural Engineer of Record (SER). This assures the prospective buyer that a registered professional is overseeing their home construction. It further makes available to the builder a readily accessible resource for use as issues arise and it may eliminate the need for Code authority inspections in some provinces. At the end of construction and final review, documentation is issued attesting to compliance of the home with the **Designed ... for safer living®** program.

Built for Performance

There are two main ways that buildings are built to construction codes. The most common is the prescriptive approach, where a single level of performance is selected and then detailed engineering descriptive specifications and tables are generated to produce the desired results. A new field of performance-based engineering has been introduced recently. It allows for a number of calculated performance options. By using Part 4 of the Code as well as Part 9, these options become available, which are more suitable to unique characteristics of the home and the desired result with respect to damage limitation following an earthquake.

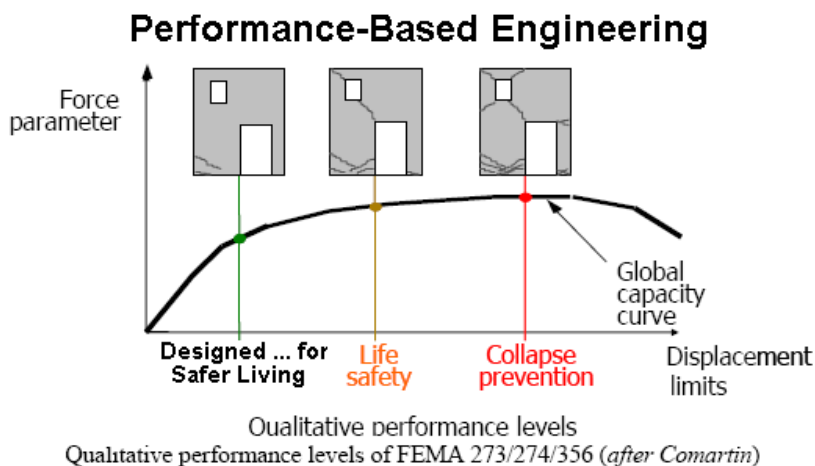

Protecting the Most Important Asset

The National Building Code of Canada is designed to protect the lives of building occupants from a wide array of hazards, including an earthquake. From a seismic point of view, the Code aims to avoid structural collapse and the loss of life that may result from strong ground motion. The current dominant system of wood frame construction produces a home, which has generally been shown to have a low rate of structural failure during earthquakes.

However, a home that adheres to the building code can experience significant damage. A home is the single largest asset most people possess. It also represents a strong sense of security. Anything that threatens significant damage to one's home is of considerable concern.

The significant value of a home indicates that simply building for life safety is not enough for many Canadians. The potential damage that will still result is no longer acceptable to many. The costs associated with the damage to the home and possible loss of use for long periods is always born partially by the homeowner. Because of the regional nature of the impact of an earthquake, recovery is expensive due to demand-based inflation and the ability to find suitable temporary housing may be limited. It is therefore more important than ever before, to reduce the risk and therefore cost of earthquake damage, by making some relatively small, but strategic improvements during the construction of a new home.

The Engineering Design Process

The NBCC specifies where earthquake measures are required in homes with seismic hazard charts (see Appendix A). A **Designed ... for safer living®** home complies with those requirements. However, because Part 4 of the Code is used, soil types and special site conditions such as sloping terrain are also taken into account during the design process. Local zoning regulations often ignore difficult site conditions, which can then be dealt with during the design process.

During the design engineering process, seismic force calculations may be generated at various locations in the home, for various building components, based on the procedure found in Part 4 of the Code and supporting appendices.

With the **Designed ... for safer living®** home, the builder has the support of an experienced engineer when needed throughout the construction process. This can speed the building schedule and eliminate costly delays and changes. Because the engineer is involved from the beginning, design changes can quickly be accommodated. From a marketing point of view, the engineered, **Designed ... for safer living®** home assures quality control during construction and a certified product on completion.

Flexible Quality Design

Because each **Designed ... for safer living®** home is built under Part 4 of the Code, virtually any desired design can be analysed and the necessary details added, in order to meet the requirements of the program. Occasional economic tradeoffs may be required, although most can be eliminated through innovative design and engineering.

As the **Designed ... for safer living®** home runs ahead of current general construction practice, it should appeal to buyers, as it is more likely to hold its value.

Seismic Forces and Building Response

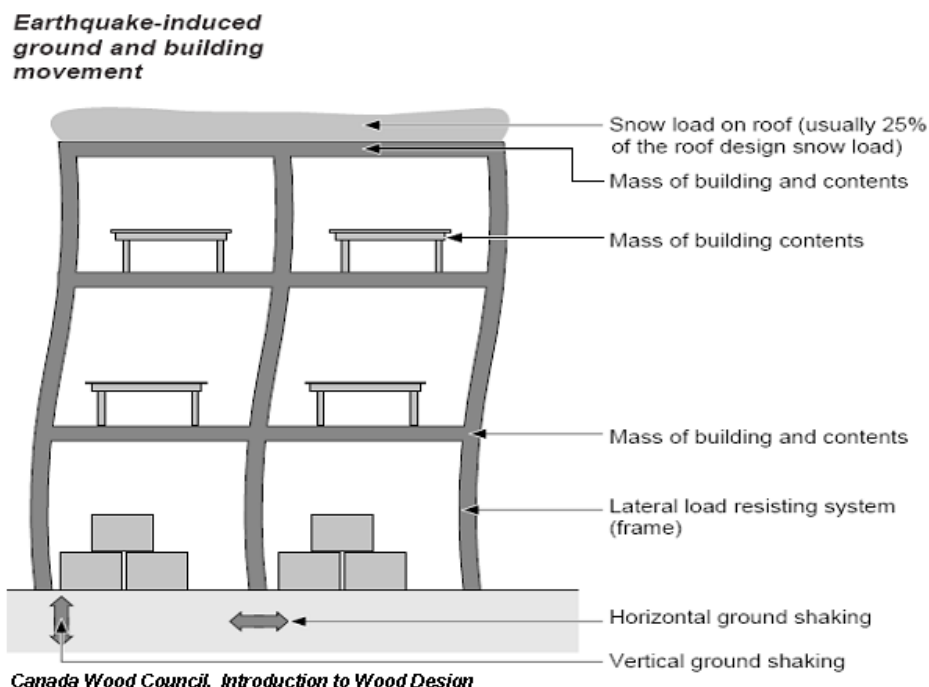

Earthquake waves generate ground acceleration in horizontal and vertical directions, which try to push the home, causing it to **SLIDE** off the foundation. This is a **SHEAR** force or base shear, applied in a horizontal plane at the foundation level. Effective anchoring and connectors avoid separation failure.

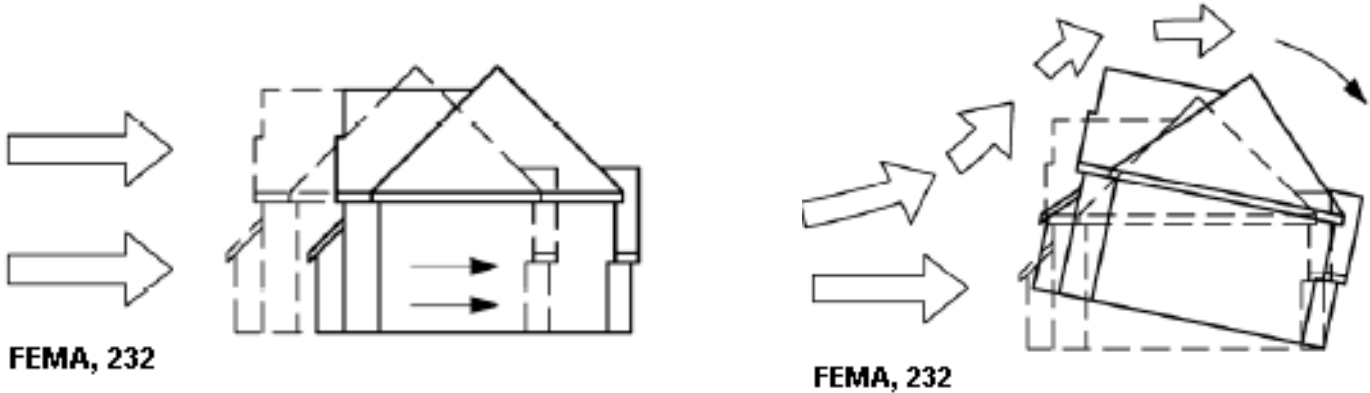

These same forces also threaten the home with **OVERTURNING**. This translates into vertical uplift and tensioning of the anchors on the side nearest the incoming waves. At the same time, the opposite side of the structure experiences compression. Once again, the anchors and connectors get a workout as the building experiences overturning forces.

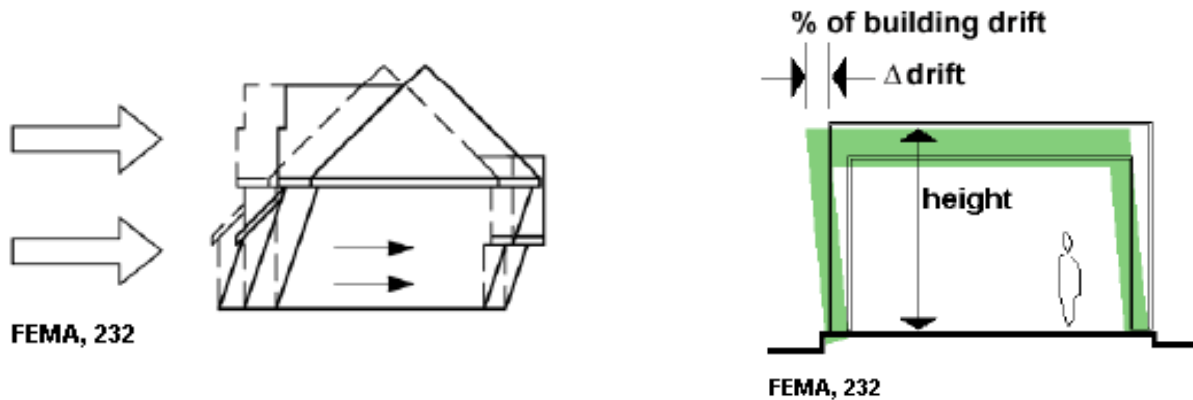

Wood frame buildings are typically more flexible than masonry or concrete structures. They are a bit like a fly fishing rod with the energy traveling up the building with a frequency, which causes the floors and roof area to displace differently from each other and the foundation. This phenomenon is called **RACKING** and results in **DRIFT**, which buildings are designed to tolerate it within limits. This flexibility can actually dissipate seismic energy, relieving stress on key connection points. If drift becomes excessive, an out-of-plane failure can occur. Drift in a building is calculated and stiffness in the form of shear walls or bracing can be added to remedy an identified problem such as a “soft storey,” where a weak floor with large openings for a garage or windows represents an unnecessary seismic risk.

Load Path Through Building Components

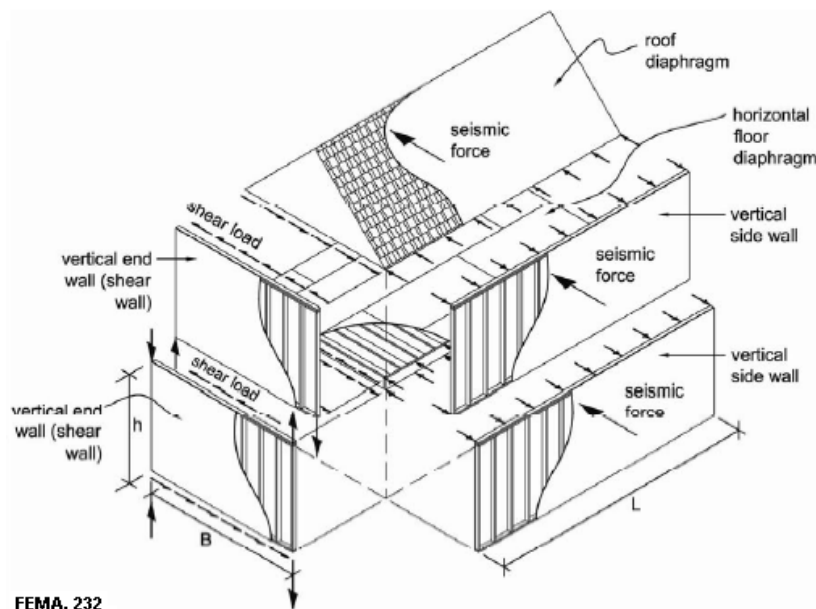

Buildings are engineered for dead and live loads of the building materials and contents. A design develops alignments, so that the weight is effectively transferred down through the structure to a solid foundation on stable soil. This is called a **LOAD PATH** and effective design of its many routes is critical to seismic performance. This results in the development of seismic force resisting systems (SFRS), which help protect the home from excessive damage during strong ground motion. Care must be taken to achieve the “sweet spot” between a structure, which is too flexible and prone to out-of-plane damage and one, which is too stiff and places undue stress on connection points.

The House You Want AND Seismic Performance

Interesting and unusual design does not preclude improved seismic performance. Large window openings, asymmetrical floor plans, cantilevered overhangs, unusual weight loading and excessively open interior spaces present engineering challenges and may increase costs, but can all be accommodated in a **Designed ... for safer living®** home. Sophisticated software can automate the enhanced engineering process and keep costs under control.

Safety Inside The Home – Protection of Contents

The nonstructural elements in a home may slide, topple and hammer on other objects during the strong ground acceleration of an earthquake. Further, excessive structural drift can cause piping system breakage. Anything not fastened to the structure will attempt to stay where it is through inertia, while the moving house runs into it. This scenario can result in flooding, fire, impact damage to other contents and injury to occupants.

The **Designed ... for safer living®** program utilizes the Building Code and the Canadian Standards Association's (CSA) S832-06 **Standard for Seismic Risk Reduction of Operational and Functional Components (OFC) of Buildings** to generate the details necessary to secure the equipment that is built into the home at the time of delivery to the owner. At the time the home is furnished, the homeowners are encouraged to have their possessions restrained in order to complete the safety system.

There are a few enhanced features included in the *Designed ... for safer living*® home, which are not covered by the Building Code. These include:

- A seismic automatic gas shut off valve.
- Windows with laminated glass on the inside pane of the double glazed unit and on both panes in egress areas where glass might fall into departure pathways.

5 HURRICANE / TORNADO HIGH WIND CRITERIA

5.1 FOUNDATION

5.1.1 Foundation Walls to Footing Dowels

- .1 Provide 15M rebar dowels between footing and foundation walls spaced at maximum 4' (1.2m) on center (o.c.).
- .2 Dowel length shall be 24" (600mm) vertical and 12" (300mm) horizontal.
- .3 Foundation Wall reinforcing as per Architectural/Structural design plans.
- .4 Refer to other sections of this document for Exterior Walls hold-down connectors.

5.1.2 Anchor Bolts

- .1 Provide minimum 5/8" (16mm) dia. x 10" (250mm) long with 2" (50mm) hook spaced at 4' (1.2m) o.c. and within 6 to 12 inches (150 to 300mm) of the end of each sill plate.
- .2 Anchors to have a minimum 7" (175mm) embedment into the concrete. Anchor without hooks shall be embedded 18" into the concrete.
- .3 Provide 3/16" x 3" x 3" (5 x 75 x 75 mm) washers at all bolts.

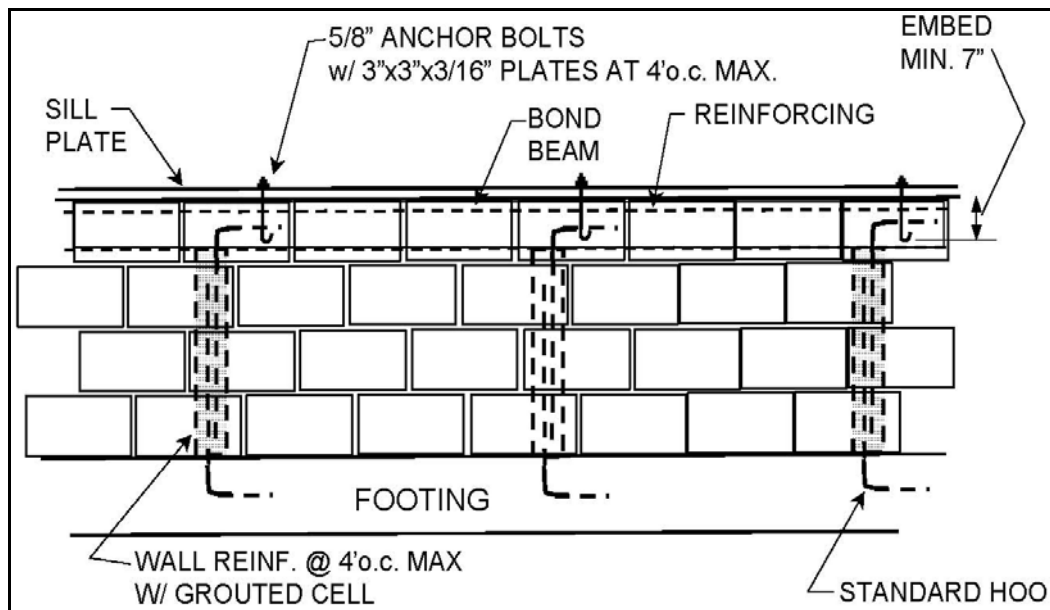

Figure 3.1: Typical foundation details for wood wall construction.

5.2 EXTERIOR WALLS

5.2.1 Sheathing

- .1 Provide minimum 15/32" (12mm) thick sheathing plywood or OSB (Oriented Strand Board) to all exterior walls.
- .2 Overlap sheathing both top and bottom sill plates at least 2' (600mm) into the wall (as shown in Figure 3.2).
- .3 Nailing schedule shall be minimum 10d nails at 6" (150mm) spacing along the 8' (2.4m) edges, 6" (150mm) staggered double row along the 4' (1.2m) edges, and 12" (300mm) spacing in the field of each structural panel.
- .4 Provide blocking where needed in all framing spaces to allow nailing around the perimeters of wall sheathing panels.

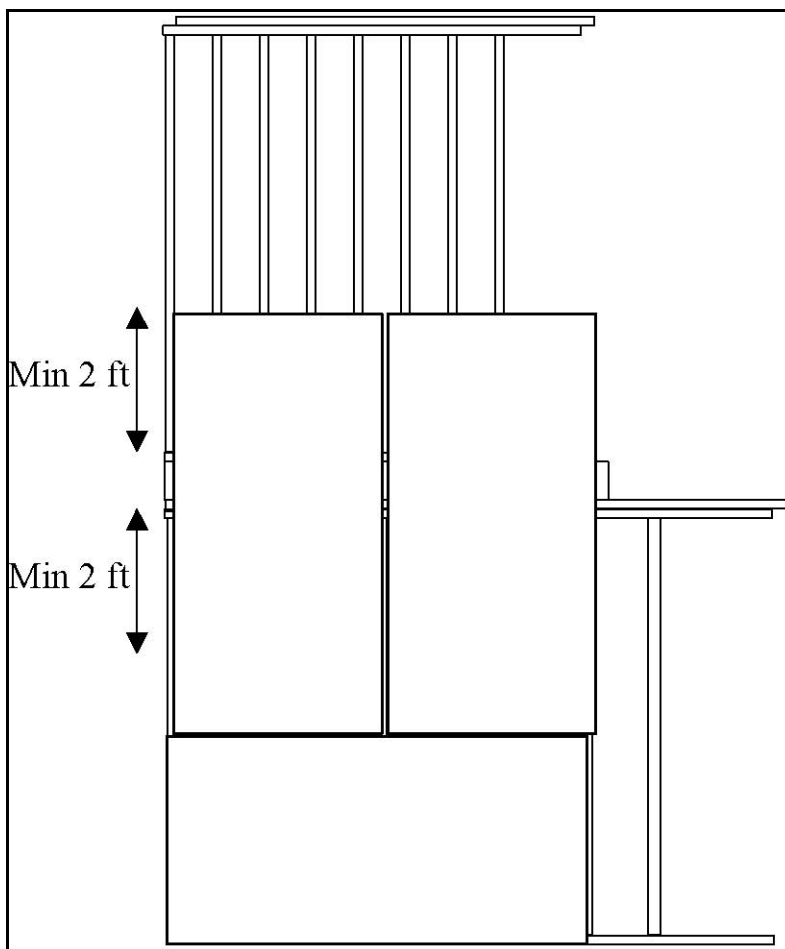

Figure 3.2: Example of how sheathing should overlap inter-storey connection by at least 24 inches (600mm).

5.2.2 Exterior Walls Hold-Down

- .1 Provide hold-down connectors at each side of wall openings and at intersections of exterior walls between main level studs and foundation walls and between first and second level as indicated.
- .2 Use model HD5A Simpson Strong-Tie or approved equal.
- .3 All hardware to be hot dipped galvanized.

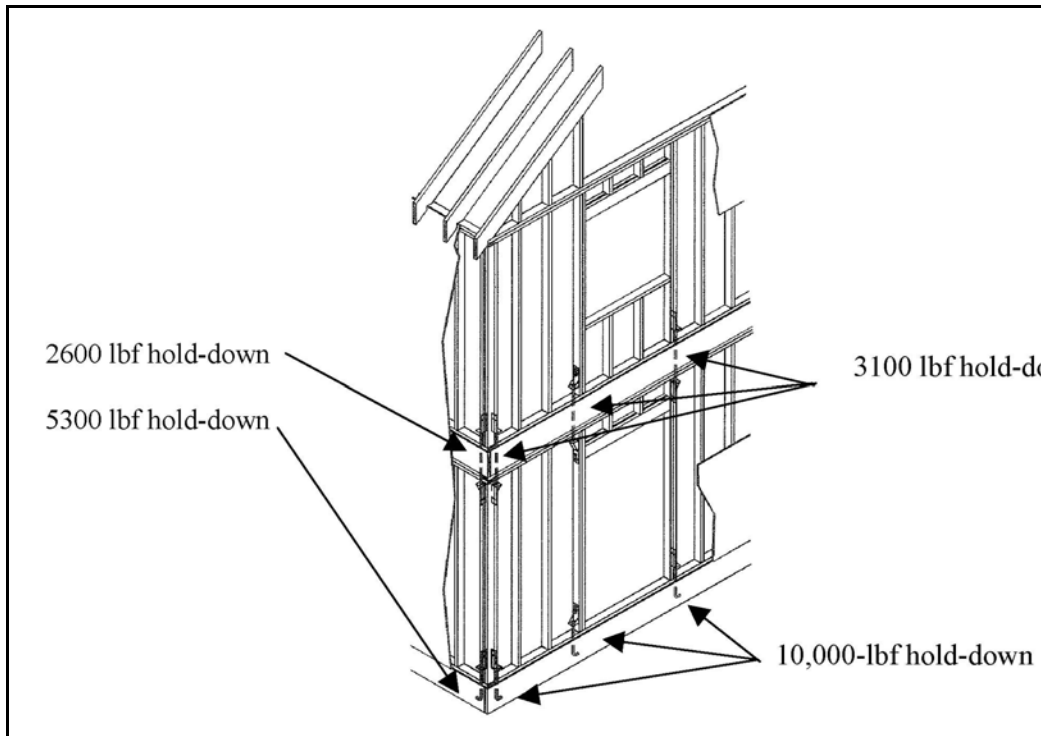

Figure 3.4: Typical Locations of hold-down connectors on 2-storey house (adapted from SSTD10-99 from Southern Building Code Congress International).

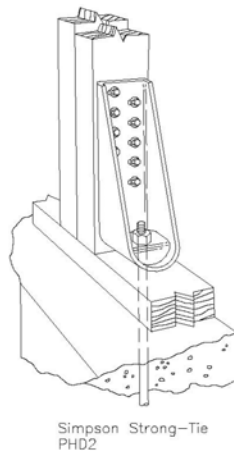

Figure 3.5: Examples of hold-down connectors from Simpson Strong-tie.

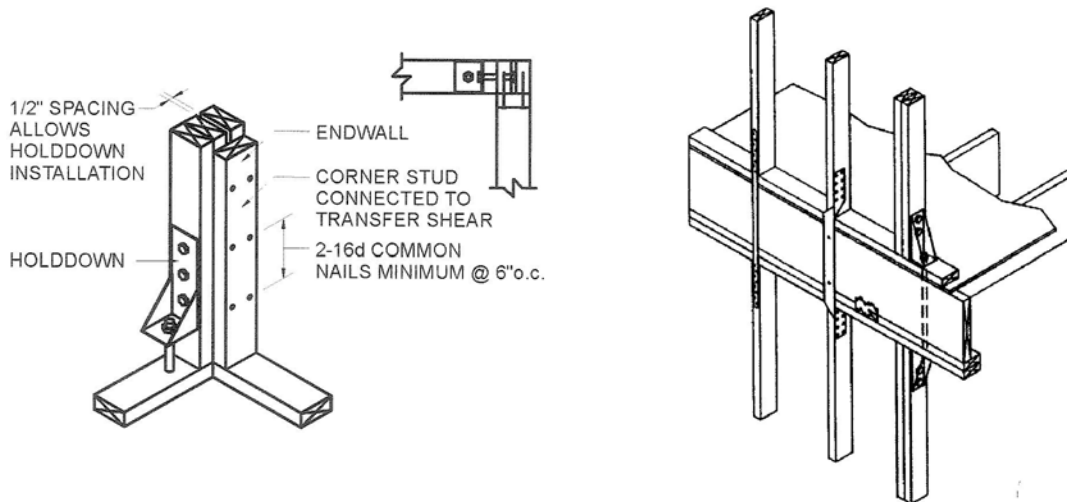

Figure 3.6: Example of single hold-down connection detail at corner. When used on the first of two stories, reduce 16d nail spacing to 4" (100mm).

Figure 3.7: First to Second storey hold-down installation examples. (adapted from SSTD10-99).

5.2.3 Inter-storey connections

- .1 Provide MSTA 36 Metal Strap between 2nd storey to 1st storey at every 48 inches (1.2m) or every 3rd stud along exterior walls.
- .2 Straps to be sheathed with continuous wood structural panels (either plywood or OSB).
- .3 Figure 3.8 shows four types of acceptable strapping.
- .4 Sheathing shall be installed so that horizontal joints between the panels are at least 2' (600mm) above/below the floor connection as shown in Figure 3.2.

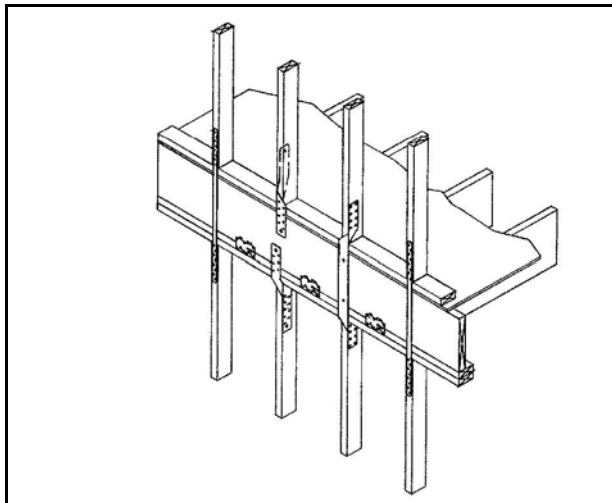

Figure 3.8: Metal Strapping used for inter-storey connections

5.3 FLOORING

- .1 Provide full depth 2" (50mm) x blocking in the first two spaces between the floor joists at each end of the floor diaphragm.
- .2 Space blocking a max of 4' (1.2m) on center and shall correspond with the joints between subflooring panels for edge nailing purposes.
- .3 Subflooring shall be nailed to floor framing at 6"/12" (150mm/300mm) spacing on the 1st floor and 4"/12" (100mm/300mm) spacing on the 2nd floor for shear resistance.

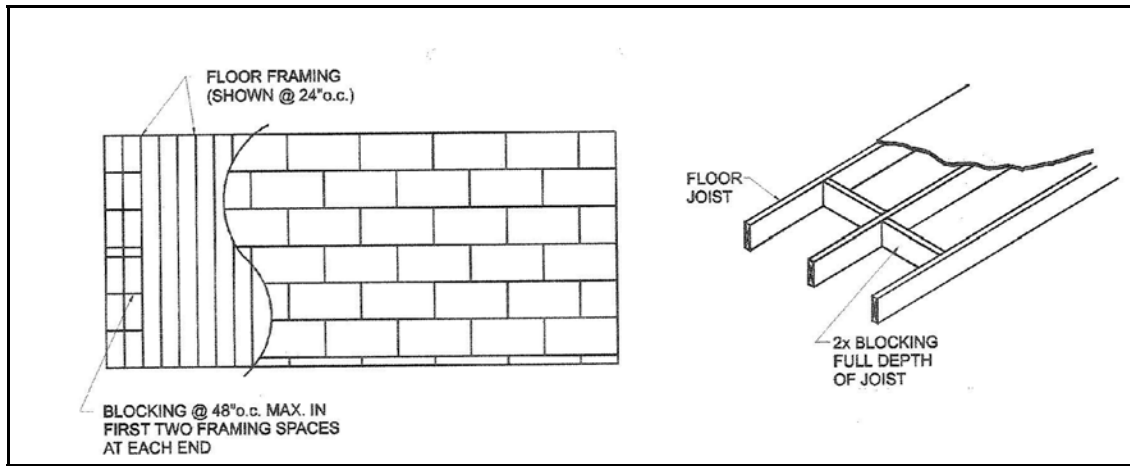

Figure 3.9: Required blocking of floor joists for wood frame floors (SSTD 10-99).

5.4 ROOF-WALL CONNECTORS

- .1 Provide Model MTS x length to suit connectors (Simpson Strong-Tie or approved equal), between each roof trusses/rafters and wall framing.
- .2 Connectors shall wrap over the top of the roof truss or rafter and be installed according to the manufacturer's recommendations.

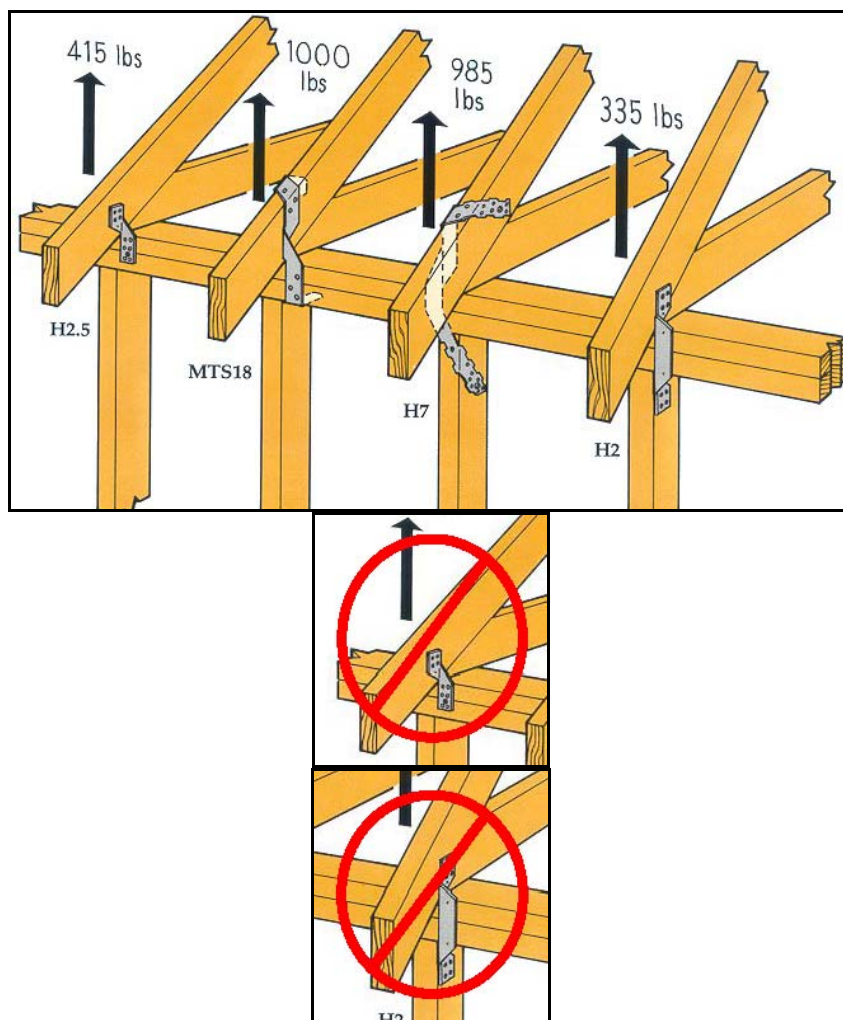

Figure 3.10: Strap types used in wood construction. Note that the non-wrapping clip styles on the left and right are not accepted by the **Designed ... for safer living®** program.

5.5 ATTACHED STRUCTURES

5.5.1 Post Base

- .1 Provide CBS 66 Post Base Connection (Simpson Strong Tie or approved equal) at each patio posts.
- .2 Provide 3/4" (20mm) diameter threaded steel rod complete with washer and extend inside brick base. Rod to be embedded min 18" (450mm) into concrete foundation.
- .3 All metal components shall be hot-dipped galvanized or stainless steel.



Figure 3.11: Connection of column on porch to foundation with post anchor.

5.5.2 Post Cap

- .1 Provide PC 66 Post Cap (Simpson Strong Tie or approved equal) at each patio post.



Figure 3.12: Strapping of top of porch column to supporting beam.

5.6 ROOF TRUSS AND GABLE BRACING

5.6.1 Lateral Bracing of Bottom Chord

- .1 Install 2"x4" (38x89mm) horizontal braces, running perpendicular to the bottom chords of the roof trusses, spaced at 4' (1.2m) on center and extending back 8' (2.4m) from the gable end wall.
- .2 Secure braces with minimum two (2) 16d nails (3.5" long) at each truss chord and four (4) 16d nails into the blocking in the first framing space, as shown in Figure 3.13.
- .3 The lateral braces must be aligned with studs in the end wall below so that it is possible to connect the braces to wall studs using metal strapping.

5.6.2 Bottom Chord Anchoring for Uplift

- .1 Provide HL metal straps (Simpson Strong-Tie or approved equal) at each lateral brace as illustrated in Figure 3.13.
- .2 In addition, for wood construction, the wall sheathing shall overlap the connection between the end wall and gable truss/frame by at least 12" (300mm) as shown in Figure 3.15.

5.6.3 Cross Bracing

- .1 Provide cross bracing between the bottom and top chord of the trusses.
- .2 Cross bracing to be installed at the same spacing as the lateral bottom chord braces described above (every 4' (1.2m)).
- .3 Keep orientation of the X in the vertical plane. Ensure that the connection between the cross braces and trusses is done into the side of the top chord and bottom chord of the trusses, as shown in the inset of Figure 3.16.

5.6.4 Top Chord Bracing

- .1 Install 2"x4" x 8' long (38x89mm x 2.4m) blocking along the top chords of gable ends at all locations where cross bracing is installed (i.e., with a horizontal projection of not more than 48" o.c. (2.4m)).
- .2 This bracing shall be constructed in a manner that is identical to the bottom chord bracing, with the exception that the metal strapping is not required. Proper installation of top chord bracing is illustrated in Figure 3.13.

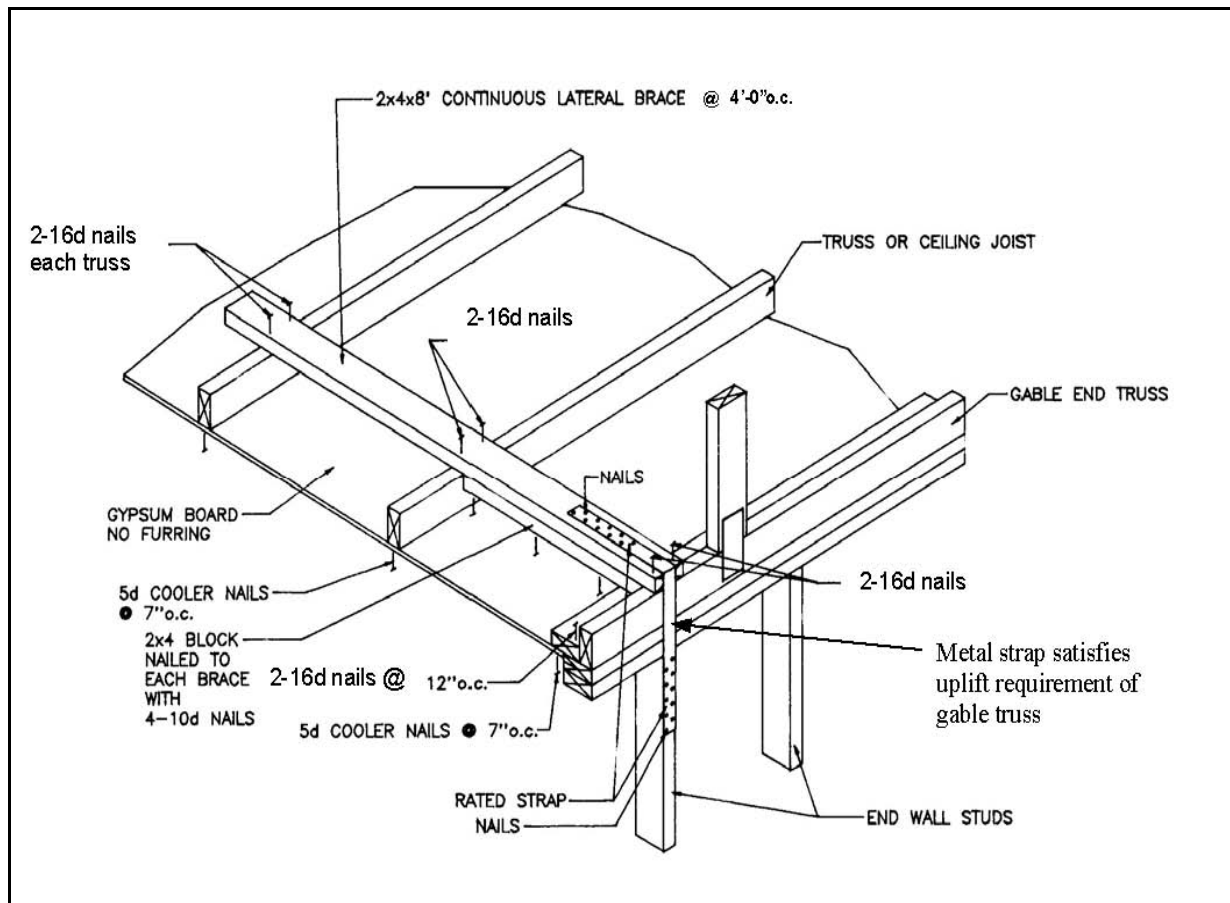

Figure 3.13: Horizontal Lateral Bracing Construction Details.

Alternative to Metal Straps for Gable Truss

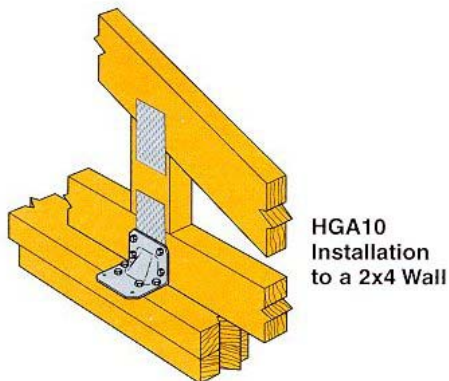

Figure 3.14: Strong Wind Gusset Angle is designed to transfer uplift and lateral loads from gable end truss to the wall below (Simpson Strong Tie, 2000). This can be used as alternative to metal strap in Figure 3.13.

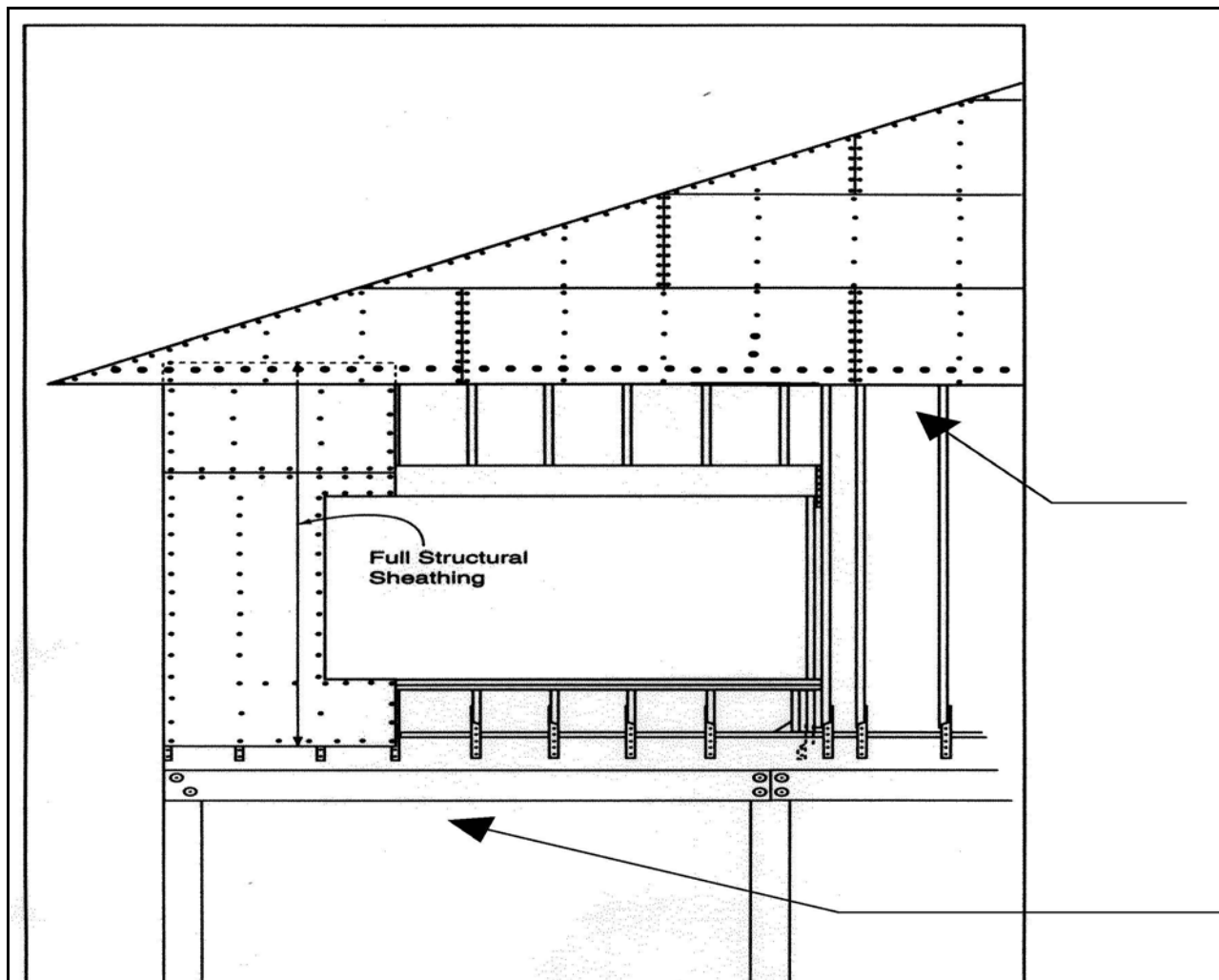

Figure 3-15: Example of how wall sheathing should overlap the gable w

Figure 3.15: Example of how wall sheathing should overlap the gable wall-side wall connection.

Note: 1. Sheathing overlaps bottom plate.

2. Sheathing overlapping the gable-side wall connection by 12" (300mm).

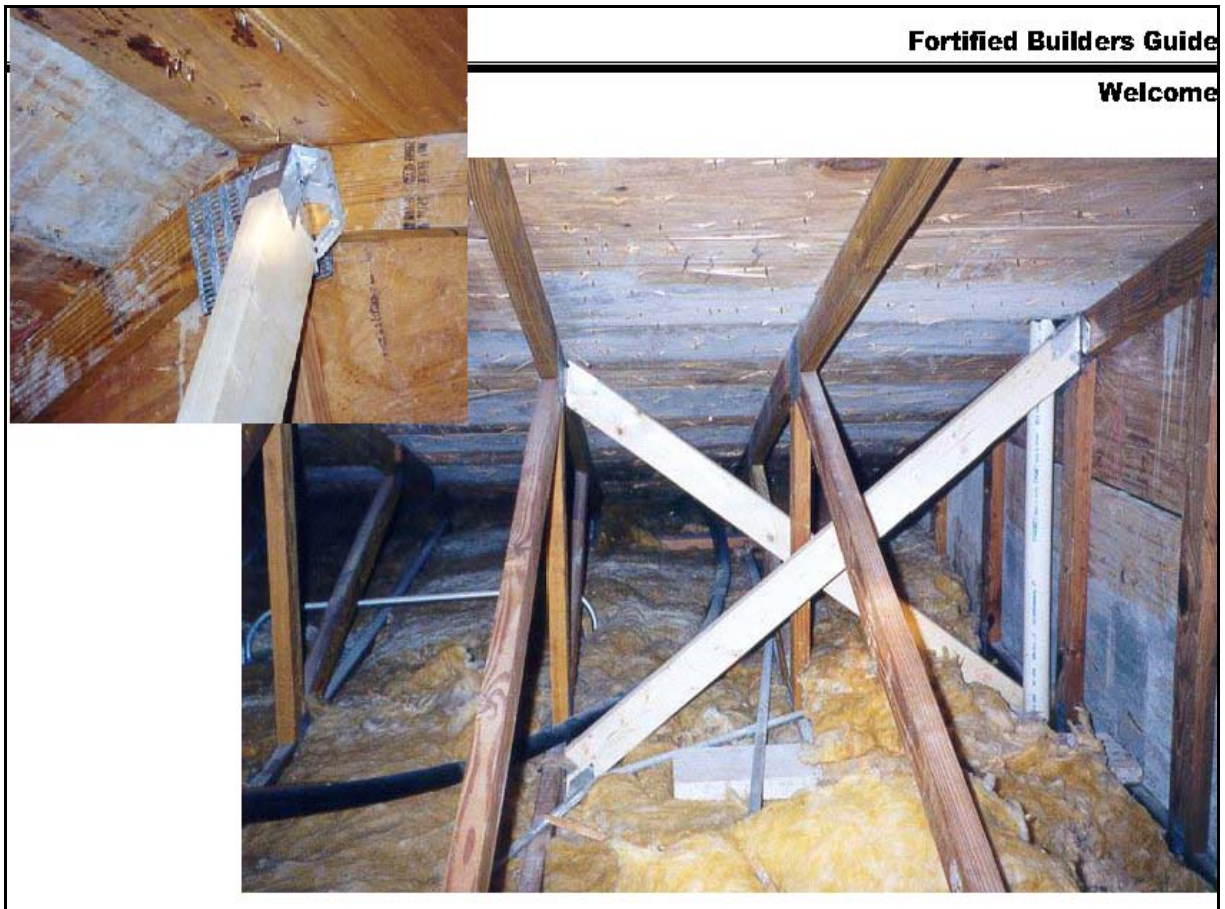

Figure 3.16: Gable End Wall Cross Bracing.
[Inset: Cross Bracing should connect to truss as close to the sheathing as possible. In this case, a special metal connector was used to make installation easier in existing attic] Top and bottom chord bracing not shown.

5.7 ROOFING

5.7.1 Roof Sheathing

- .1 Roof decks must be fully sheathed with wood panels having a minimum thickness of 5/8" (16mm), either plywood or OSB may be used.
- .2 Sheathing shall be attached with 8d ring shank, 2.5" long x 0.120" diameter (63mm x 3mm), nails at 4" (100mm) on center on any panel adjacent to a gable end (those panels shown in color in Figure 3.17). The same nails are required at a spacing of 6" (150mm) on center everywhere else on the roof deck. Note that the nails must be a full 2.5" (63mm) long to qualify.
- .3 Roof sheathing must be nailed to roof trusses/rafters, as well as to the blocking formed by the gable end brace of the top chord. A minimum withdrawal design value of 60 lb (0.27 KN) per fastener is required of all nails used to attach roof decking.
- .4 If required due to roof geometry, piecework (panels ripped lengthwise to a width less than 4' (1.2m)) is to be located in a strip located at least 4' (1.2m) away from the ridge or eaves. This is illustrated in Figure 3.17.
- .5 All nails shall be installed such that they do not protrude out the side of the framing members as shown in Figure 3.18.

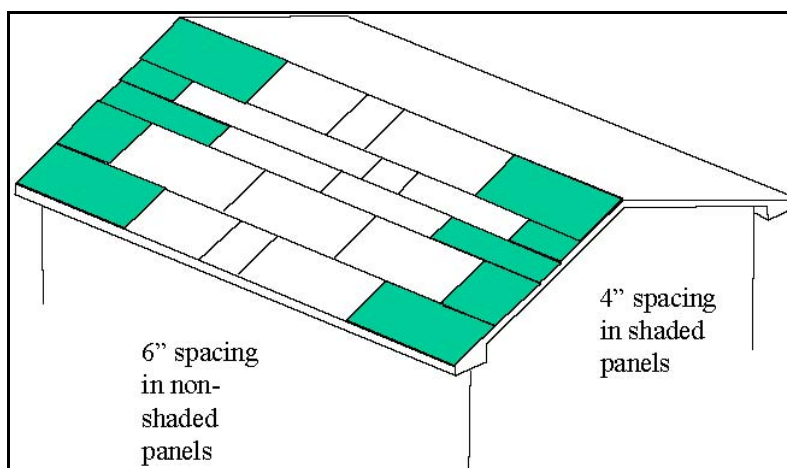

Figure 3.17: Nail Spacing requirements for plywood or OSB roof deck

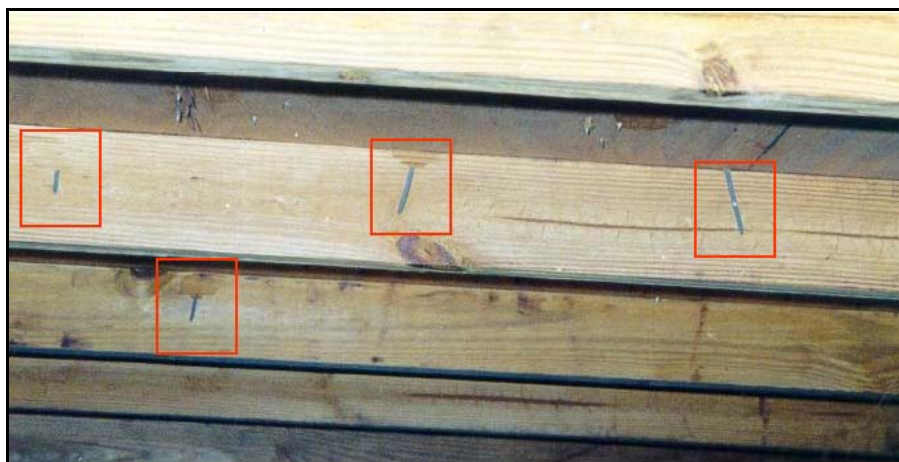

Figure 3.18: Avoid sidesplitting nails in deck to rafter connections. Note frequency of misses in this case causes roof deck to be very vulnerable to wind damage.

5.7.2 Roof Panel Joints

- .1 All roof panel joints shall be covered with a self-adhering polymer modified bitumen tape of at least 4" (100mm) width to provide secondary water resistance. Alternatively, a self-adhering polymer modified bitumen membrane may be used in lieu of both the underlayment and self-adhering tape. Self-adhering polymer modified bitumen tape and membranes must comply with CSA A123.22-08 "Standard Specification for Self-Adhering Polymer Modified Bituminous Sheet Materials Used as Steep Roofing Underlayment for Ice Dam Protection." (ASTM D1970).



Figure 3.19: Installation of secondary water resistance using self-adhering strips.

5.7.3 Roof Underlayment

- .1 At a minimum, roofing underlayment shall consist of either a single layer of 30# felt with a minimum 2" (50mm) overlap or two layers of 15# felt with a 19" (475mm) overlap. Both underlayment application methods require a minimum 6" (150mm) end lap. Underlayment to CSA A123.03-05 "Asphalt Saturated Organic Roofing Felt". Alternatively, a self-adhering polymer modified bitumen membrane meeting CSA A123.22-08 may be used in lieu of both the underlayment and self-adhering tape.
- .2 Nail spacing shall be no greater than 6" along the laps and 12" (300mm) in the interior of each strip using low profile roofing nails with load distribution disks or capped head nails.
- .3 Roofs within 3000 feet (1000m) of salt water require hot dipped galvanized fasteners for attachments of all roof coverings, including the underlayment.

5.7.4 Roof Covering

Roofing systems on homes built under the *Designed ... for safer living*® program must be built to withstand a design 3-second gust wind speed of at least 130 mph (210 km/h).

- .1 Asphalt shingle roof coverings shall meet one of the test standards listed below, and be installed in accordance with the manufacturer's recommendations for high-wind regions.
- .2 Each strip shall be attached to the roof deck with no less than 6 roofing nails. The tabs of shingles adjacent to, or along the eaves, hips, and ridges must be manually adhered to the underlying surface with at least four 1" (25mm) diameter dabs of asphalt roof cement per tab. Along rake edges, shingles shall be manually adhered to the underlying surface with 1" (25mm) diameter dabs of asphalt roof cement at spacing of 2" (50mm) on center. Shingles – including hip and ridge materials – must meet one or more of the following standards:
 - ASTM D3161. Note: If materials tested under this standard are used, it must be verified that they were tested to a minimum wind velocity of 130 mph (210 km/h).
 - UL 2390 and ASTM D6381. Note: These standards must be used together in order to determine whether or not the shingles will be able to withstand a design wind speed of 150 mph (240 km/h).

All roof coverings, regardless of type, must be installed in accordance with the manufacturer's recommendations for high wind regions.

5.7.5 Ice Dams

- .1 An additional moisture barrier shall be applied along the eaves of the roof to prevent water intrusion caused by ice dams. This shall consist of a self-adhering polymer modified bitumen membrane meeting CSA A123.22-08.
- .2 The moisture barrier must extend from the eave's edge to at least 24" (600mm) past the exterior wall line.
- .3 Where roof valleys exist, the additional moisture barrier shall extend up the entire length of the roof valley and be a minimum of 36" (900mm) in width. This additional ice dam protection is not necessary in cases where a self-adhering polymer modified bitumen membrane is applied over the entire surface of the roof deck.

5.7.6 Soffits and Fascias

- .1 All soffits and fascias shall have a minimum design pressure of +33/-43 psf (+1.58/-2.06 kpa), as determined by the AAMA 1402-86 test standard. Unsupported soffit lengths shall not exceed the maximum dimensions of the tested configuration, as reported by the manufacturer. All soffits shall be fabricated from heavy gauge material and shall be installed according to the manufacturer's recommendations for high wind regions.

5.8 ALL OPENINGS: FLASHING AND INSTALLATION

Windows and doors are installed according to manufacturer's specifications. The **Designed ... for safer living®** program has specific requirements for flashing around all windows and doors in wood frame walls that may exceed requirements from manufacturer. Confirm that flashing meets the following specifications. Note that there is no requirement for flashing in masonry walls.

The steps presented below are consistent with Method "B" from the AAMA InstallationMasters™ guide for windows with mounting flanges and weather resistant barriers applied after installation of the windows. These recommended steps are presented in a step-by-step format as well as in Figure 3.20. Other types of windows or installations methods are acceptable as long as the AAMA Installation Masters™ guide, CSA 101/I.S or ASTM E 2112-01 – Standard Practice for Installation of Exterior Windows, Doors, and Skylights, recommends them.

The following five sections give instructions for installing windows with mounting flanges.

Step 1: Sill Flashing

1. Install a 9" (225mm) wide piece of flashing flush with the rough opening of the window allowing the flashing material to overlap the sheathing below.
2. Fasten with staples at the top edge and do not remove release paper until weather resistant barrier is installed in Step 5.
3. Extend the flashing 9" (225mm) beyond the rough opening at the side jambs.

Step 2: Jamb Flashing

1. Install 9" (225mm) wide flashing on the side jambs of the windows opening letting the material extend above the top opening 8.5" (213mm) and extending below the sill for a minimum of 9" (225mm).
2. Jamb flashing should overlap the sill flashing.
3. Attach entire length except for lowest 9" (225mm) to allow weather resistant barrier to be installed in Step 5.

Step 3: Install the window

1. Apply a continuous bead of sealant to back of perimeter of mounting flange in line with the pre-punched holes.
2. Install window in wall according to the manufacturers recommended schedule.
3. Install window frame while the caulk is still wet. Drive the nails in all the way; never bend them over.
4. Cover up any pre-punched holes in nailing flange with sealant.

Step 4: Head Flashing

1. Apply a bead of sealant to outside of top mounting flange and then install 9" (225mm) wide flashing overlapping nailing flange.
2. Head flashing must cover top edge of jamb flashing and should extend a minimum of 9" (225mm) past side jambs of window.

Step 5: Weather Resistant Barrier

1. Install weather resistant barrier consisting of house wrap or building paper in weather board fashion starting from base of the wall and working upward.
2. The first course of weather resistant barrier should be tucked up under the sill and loose ends of jamb flashing. Attach sill and jamb flashing to barrier.
3. Apply next courses of barrier to overlap the jamb flashing as shown in Figure 3.20.

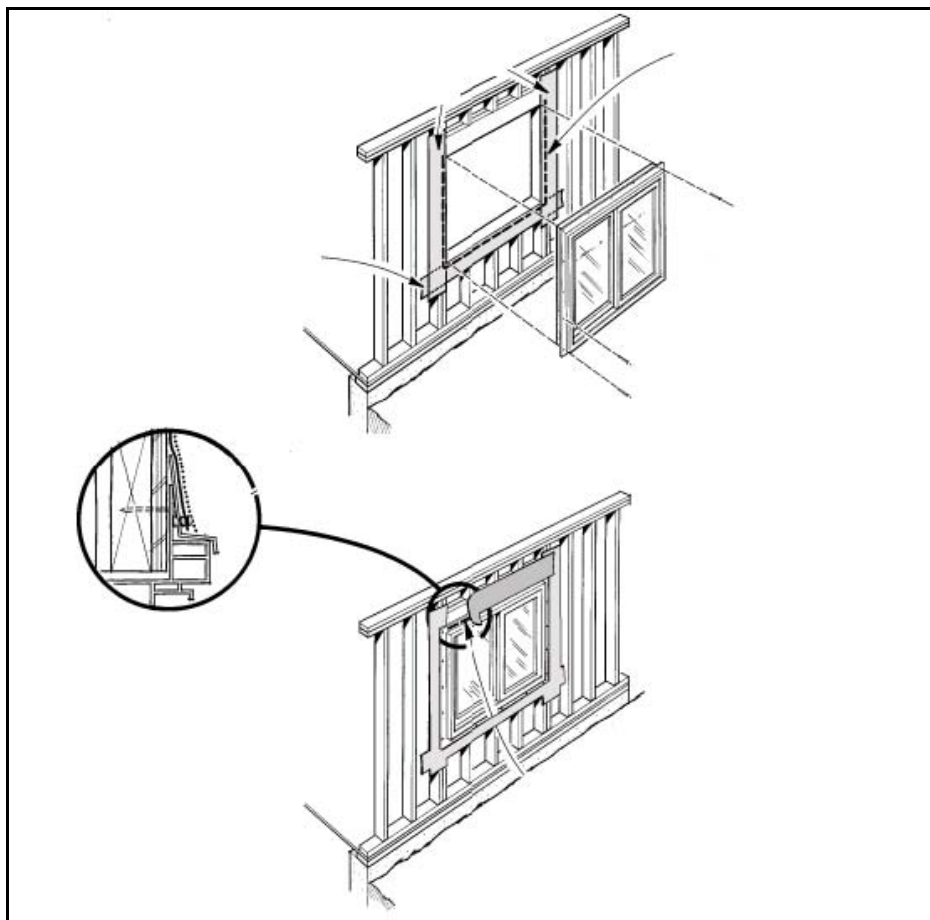

Step 2: Jamb Flashing - Install 9" wide vertical strips of flashing at either side. Extend 8.5" above head of rough opening. Overlap the sill flashing by 9".

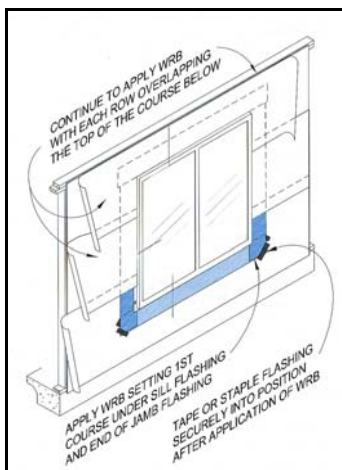

Figure 3.20: Water Penetration Resistant Window Flashing Details (diagram provided by AAMA).

5.9 ELEMENT THAT DIFFER BY WIND PERIL

All entry doors, windows, skylights, patio doors, and garage doors must be tested and certified to meet impact resistance and pressure standards. If the units themselves are not tested, they must be protected by a system (storm shutter or screen) that meets the impact resistance standards. Systems must be compliant with ASTM E 1996 "Standard Specification for Performance of Exterior Windows, Curtain Walls, Doors and Impact Protective Systems Impacted by Windborne Debris in Hurricanes"

5.9.1 Openings: Doors, Windows, Skylights, and Garage Doors

In the tornado / hail region, all openings must be rated for a minimum design pressure of positive or negative 50 psf (2.4 kn/m²) as specified by the North American Fenestration Standard, which combines the AAMA/NWWDA 101/I.S.2 and AAMA/WDMA 1600/I.S.7 test standards and CSA 101. Either the WDMA (Window and Door Manufacturers Association) "Hallmark Certification" or the AAMA "Gold Label" Certification Program shall certify these openings with a minimum DP rating of 50 psf (2.4 kn/m²).

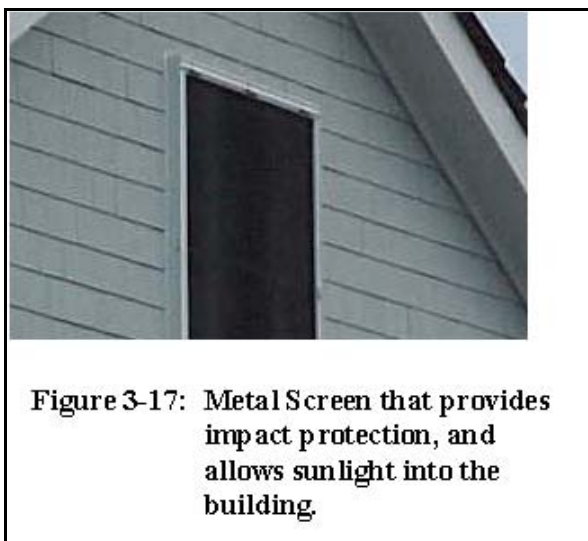

Figure 3.17: Metal Screen that provides impact protection, and allows sunlight into the building.

Openings (including doors, garage doors, skylights, and windows) greater than 32 square feet (3 m²) in area must be impact-resistant or protected by a passive protection system that complies with one of the impact standards. Passive protection means that the window or door can withstand wind-borne debris without any external protection; i.e., shutters or screens. Window units connected by mullions supplied by the window manufacturer are considered to be separate units in the determination of area for impact criteria. Two double hung units side by side that are 4' x 5' (1.2m x 1.5m) each are considered to be separate units with areas of 20 square feet (1.86 m²) instead of a single opening that is 40 square feet (3.7 m²). In this case the double hung windows would need to meet a DP of 50, but not need impact protection.

When one examines a double door, or a double slider, the rough opening of the unit should be considered. The support between the door slabs is not a fixed permanent one, and thus is considered to be different than the mullions in window systems. Thus the double door or slider will often exceed

the 32 square foot (3 m²) limit and therefore will need to meet the impact criteria.

5.9.2 High Wind Region

All openings must be rated by WDMA Hallmark or AAMA Gold Standard certification for a minimum design pressure of positive or negative 50 psf (2.4 n/m²). All openings must be flashed or properly caulked if installed directly to masonry.

6 WILDFIRE REGION CRITERIA

The Wildland/Urban Interface is an area where structures and other improved property meets or intermingles with wild land or vegetative fuels. Wildfires are a natural hazard in any forested and grassland region in Canada. The regions with the highest wildfire occurrence are British Columbia, and the Boreal forest zones of Ontario, Quebec, the Prairie Provinces, and the Yukon and Northwest Territories.

Site Evaluation

An Inspector working on behalf of **Municipality** or the **Designed ... for safer living®** Program will identify the wildfire hazard level for the site by examining the following items:

- Ingress and egress into subdivision.
- Road widths.
- Road condition.
- Road terminus.
- Surrounding vegetation (fuel).
- Topography/slope of surrounding area.
- History of fire occurrence due to lightning, railroads, burning debris, arson, etc.
- Building setback.
- Fire protection systems (fire hydrants).
- Utilities including gas and electric.

Each factor is assigned a point value and the cumulative value of the points determines whether the site is in a low, moderate, high, or extreme wildfire hazard setting. Note that if the hazard level is determined to be Low, then none of the wildfire criteria are applicable. For a risk assessment checklist, visit www.ibhs.org.

Some local governments have developed Wild Fire Hazard Maps with generally 4 separate ratings: Low, Moderate, High, Very High. In addition, some municipalities produce Interface Fuels treatment Strategy Map.

Wildfire Protection Criteria Common to Extreme, High and Moderate Wildfire Hazard Levels

The following items are applicable to all very high, high, and moderate Wildfire Hazard Areas. These requirements must be augmented by the hazard specific requirements that follow this section and the builder must comply with the municipal guidelines and requirements applicable to the site where the house is to be constructed.

1. A non-combustible street number at least four inches high, reflectorized, on a contrasting background, at each driveway entrance, visible from both directions of travel.
2. Firewood storage and LP gas containers must be at least 50' (15m) away from any part of the home structure, and have at least 15' (5m) of survivable space around them.
3. Non-combustible, corrosion-resistant screening with a mesh size no greater than ¼" (6mm) covering the attic and sub-floor vents. Vent openings shall not exceed 144 square inches (1 m²) at each vent.
4. Spark arrestors in all chimneys (Figure 5.1)

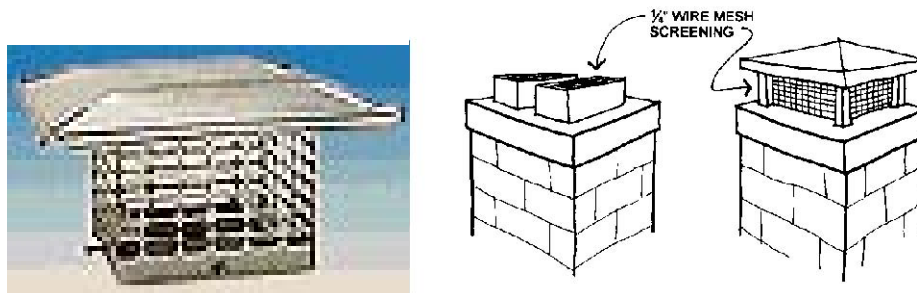

Figure 5.1: Spark Arrestor for chimney

Eaves of noncombustible materials as defined in Table 5.1. For materials not listed in Table 5.1, any material that has passed when tested in accordance with Section 8 of ASTM E 136 "Standard Test Method for Behavior of Materials in a Vertical Tube Furnace at 750°C (1382°F)" are generally considered to be non-combustible.

Table 5.1: Combustible and Non-combustible Soffit Materials

Combustible:

- Vinyl
- PVC
- Wood boards or panels less than or equal to 1/2" (12mm) thick including plywood and OSB

Noncombustible:

- Aluminum
- Wood boards or panels greater than 1/2" (12mm) in thickness including plywood and OSB

1. Gutters and downspouts of noncombustible materials. Typical aluminum gutters and downspouts are considered to be acceptable.
2. Driveways must be at least 12' (3.7m) wide with at least 13.5' (4.1m) of vertical clearance.
3. If gated, the gate must open inward, have an entrance at least two feet wider than the driveway, and be at least 30' (10m) from the road. If secured, the gate must have a key box of a type approved by the local fire department.
4. Individual Fire Extinguishers

Wildfire Protection Criteria that Varies by Wildfire Hazard Level

1. Survivable Space Characteristics

The following characteristics shall be applied in the survivable space whose extent is defined by the wildfire hazard level below:

- Grass mowed below 6" (150mm).
- Provide regular irrigation
- For trees taller than 18' (5.5m), prune lower branches within 6' (1.8m) of ground.
- Trees are 10' (3m) apart from each other.
- No tree limbs within 10' (3m) of home.
- All plants or plant groups are more than 20' (6m) apart.
- No vegetation under decks.
- Remove all dead/dying vegetation.

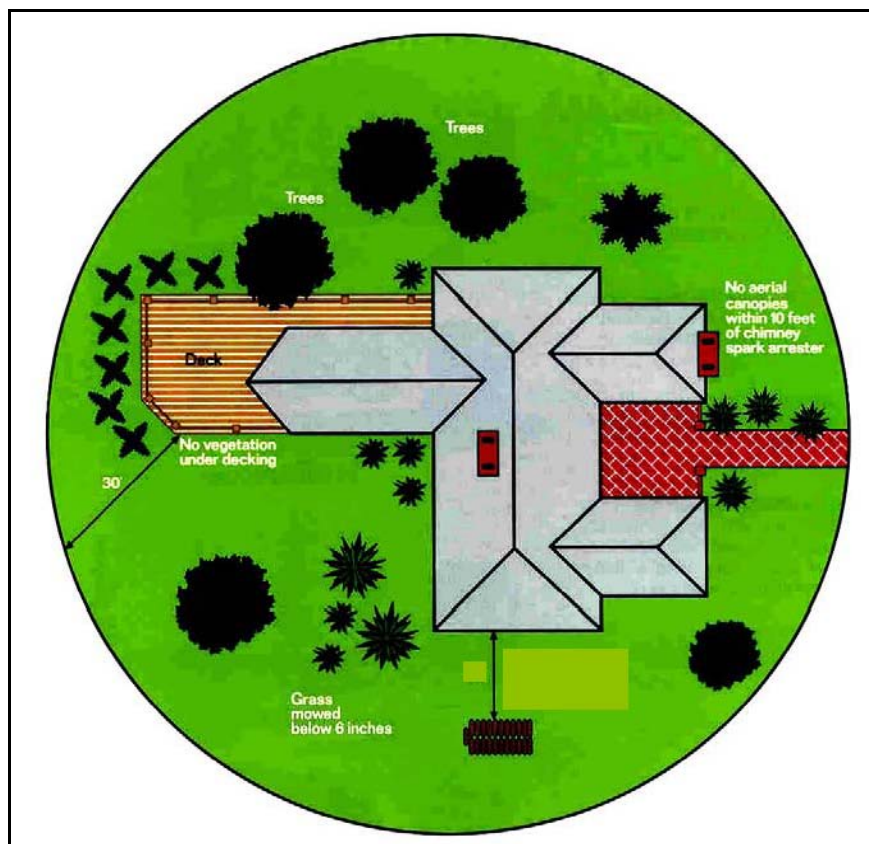

Figure 5-2: Survivable Space features (courtesy of Western Fire Chiefs Association, 1996).

2. Very High Hazard Areas

If the home is in a wild land/urban interface area and has an “Very High” hazard rating, it must have the following additional items:

- a) A survivable space of 100' (30m).
- b) A roof covering assembly with a Class A fire rating according to UL 790. Other standards that are also accepted include ASTM E 108 Class A, or UBC 15-2 ratings. Consult the product packaging or other manufacturer literature to determine if the product meets this standard. There are also publications available from the National Roofing Contractors Association that list fire ratings (and other information) by manufacturer and product name [NRCA 1999a, 1999b]. Wood shakes and wood shingles do not qualify regardless of rating.
- c) Non-combustible material enclosing the undersides of aboveground decks and balconies.
- d) No fire wood within 50' (15m) of structure.
- e) Exterior windows are double-paned glass with a tempered outside lite and non-combustible, corrosion resistant screens OR have non-combustible shutters.
- f) Exterior glass doors and skylights are double paned, tempered glass.
- g) Exterior wall assemblies must have one-hour fire resistive rating with non-combustible exterior surfaces. The following materials are considered to be Non-combustible exterior surfaces: brick veneer, concrete block, concrete, and stone.
- h) Monitored smoke alarms.
- i) In-home sprinkler system that complies with NFPA 13-D-1999: Installation of sprinklers in 1 and

2 family dwellings.

3. High Hazard Area

If the home is in a wild land/urban interface area and has a "High" hazard rating, it must have the following additional items:

- a) A survivable space of 50' (15m).
- b) A roof assembly with a Class A fire rating. Wood shakes and wood shingles do not qualify regardless of rating.
- c) Non-combustible material enclosing the undersides of aboveground decks and balconies.
- d) Exterior windows are double-paned glass and non-combustible, corrosion resistant screens OR has non-combustible shutters.
- e) Exterior glass doors and skylights are double-paned glass.
- f) Exterior wall assemblies must have one-hour fire resistive rating with fire resistant exterior surfaces. The following materials are considered to be fire-resistive: wood boards or panels greater than ½" (13mm) in thickness (including plywood and OSB), stucco, plaster, and brick or stone veneer.
- g) Non-monitored smoke alarms.

4. Moderate Hazard Area

If the home is in a wild land/urban interface area and has a "Moderate" hazard rating, it must have the following additional items:

- a) A survivable space of 30' (10m).
- b) A roof assembly with a Class B fire rating.
- c) Fire-resistive material enclosing the undersides of aboveground decks and balconies.
- d) Exterior walls are fire resistant materials. The following materials are considered to be fire-resistive: wood boards or panels greater than ½" (13mm) in thickness (including plywood and OSB), stucco, plaster, and brick or stone veneer.
- e) Non-monitored smoke alarms.

7 SEVERE WINTER WEATHER CRITERIA

Severe Winter Weather criteria specifically addresses the potential for damage from ice dams in areas prone to snowfall accumulations greater than 12 inches (300mm). Most localities in Canada are subject to Severe Winter Weather Conditions. The National Building of Canada (NBCC) provides design weather data for selected locations including temperature, snow and rain fall, wind speed, etc. In addition to the NBCC, homebuilder must consult with local authorities for applicable municipal codes and their requirements. The **Designed ... for safer living®** criteria for Severe Weather is based on the requirements of the NBCC and homebuilder must met these minimum criteria.

Mandatory Requirements:

1. Unless already included because of other risks, an additional moisture barrier shall be applied to the roof deck along the eaves of the roof to prevent intrusion caused by ice dams.
2. All drains on flat roofs shall have heating strips (heat trace) installed around them in such a way that it prevents blockage of the drains by ice or ice dams.
3. No heat source shall be installed in un-conditioned attic space.
4. No un-insulated recessed lights shall be installed.
5. All attic doors between conditioned and un-conditioned space shall be treated as exterior doors, properly insulated, sealed and weather-stripped or gasketed.
6. All hidden attic penetrations (stack vents, partition walls, electrical chases, etc.) shall be properly sealed and insulated.
7. Frozen Pipes:
 - a) Option 1: Require sufficient insulation on all exterior piping and on all piping in exterior walls, crawl spaces, attics, and basement ceilings.
 - b) Option 2: Prohibit pipes in external walls and unheated spaces.

Designed ... for safer living® homes located in areas within the freezing weather criteria boundary shall include the following requirements in addition to those of other perils:

Roof Requirements

An additional moisture barrier shall be applied along the eaves of the roof to prevent water intrusion caused by ice dams. This shall consist of a self-adhering polymer modified bitumen membrane meeting ASTM D1970. The moisture barrier must extend from the eave's edge to at least 24" (600mm) past the exterior wall line. Where roof valleys exist, the additional moisture barrier shall extend up the entire length of the roof valley and be a minimum of 36" (900mm) in width. This additional ice dam protection is not necessary in cases where a self-adhering polymer modified bitumen membrane is applied over the entire surface of the roof deck.

Attic Requirements

Specifically, severe winter weather attic requirements are:

1. No heat sources shall be installed in unconditioned attic space (i.e., ductwork, etc).
2. No un-insulated recessed lights.
3. All attic access doors located in conditioned spaces shall be treated as exterior doors, properly insulated, sealed and weather-stripped or gasketed.
4. All hidden attic penetrations (stack vents, partition walls, electrical chases, etc) shall be properly sealed and insulated.

8 FLOOD REGION CRITERIA

Floods can cause substantial damage to property and threaten human life. After a flood, governments and insurance firms are often faced with providing emergency assistance, clean-up, remediation and compensation to affected residents and businesses.

In Canada, flood requirements were originally established in 1975 as part of the Flood Damage Reduction Program (FDRP) where urban and coastal flood prone lands were mapped based on one hundred-year or greater floods. The program encouraged provincial and municipal governments to enact site specific floodplain regulations in order to regionalize and mitigate future development on the designated lands. Flood information maps are available for flood risk areas. With the implementation of this program, provinces and municipalities discouraged development on the designated flood risk areas. Depending on the locality, there were more stringent regulations based on historic flood data. Some minimum requirements practiced in flood risk zones are outlined below:

1. A minimum of 1 foot (0.3m) freeboard above the first floor entry for a 1 in 100 year flood event.
2. Flood proofing procedures including sealing all openings below floodline, surrounding the building with floodproof masonry or concrete walls or berms, using one-way valves for sewer systems and installation of electrical, communication and mechanical systems above the flood line.

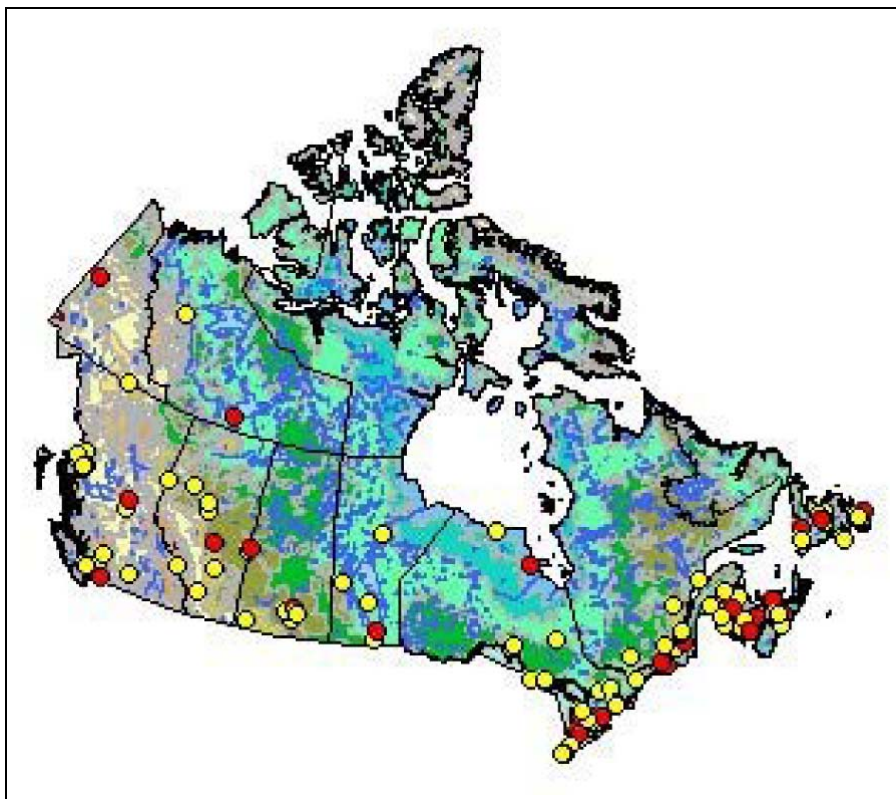

Figure 4-1: Map Location of Floods in Canada 1900-1997
(Source http://tsdmaps.gsc.nrcan.gc.ca/website/_floods/floods_e.htm).

Notes

- 1) the symbols depict the general location of a given event and in some case, the affected area was substantially larger than the symbol;
- 2) light symbols represent a single event & dark symbols represent multiple events.

Floodplains

A floodplain is defined as the land submerged by a one hundred year or larger flood. The floodplain is divided into two key areas: the **floodway** and **flood fringe**. The floodway is designated as a high risk flood hazard and flood fringe is designated as a chance of flood occurrences (see Figure 4-1).

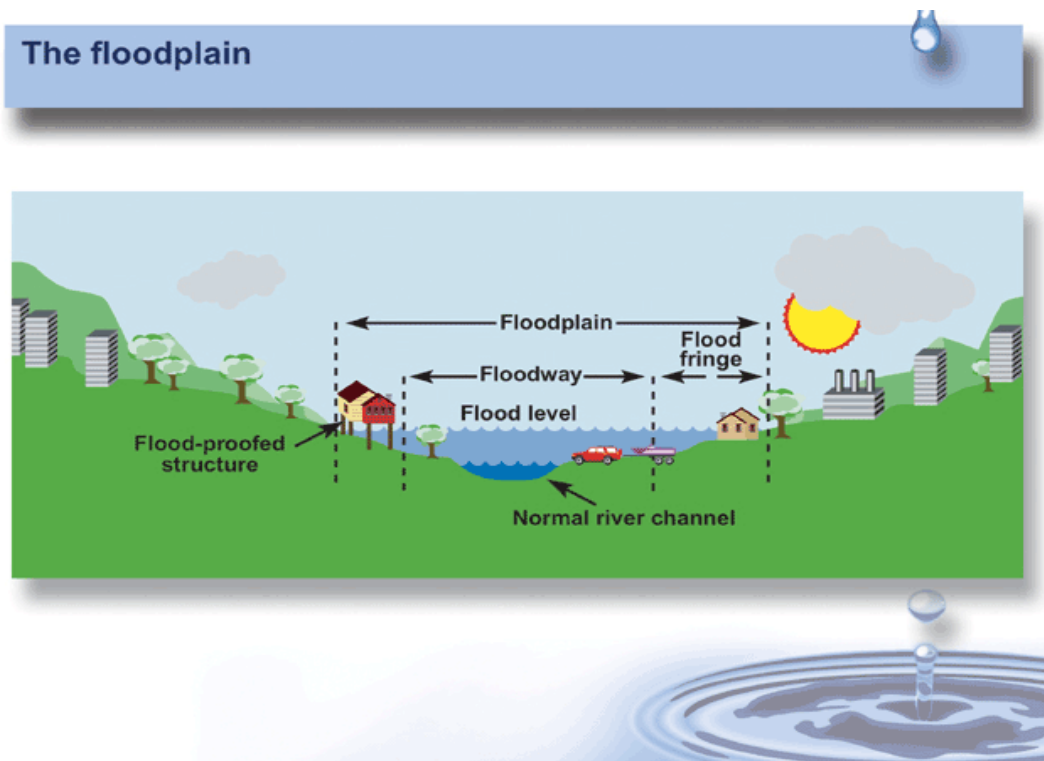

Figure 4-2: Illustration of floodplain and flood fringe (Environment Canada website, *Floods*, 3 Feb. 2009)

Generally provincial and municipal land use policies direct new buildings and land uses to areas that are not at a high risk of flooding. In lower risk areas, development needs to be of a design and with an appropriate level of protection to ensure that the risk of damage from flooding is minimized. Any development within a flood risk area should not impede water flows or exacerbate flood risk elsewhere.

It is the prime responsibility of the property owner to avoid development in areas of flood risk and, in instances where development already exists or is permitted, to undertake appropriate flood proofing. Provincial regulations and municipal zoning by-laws and all other agencies with development control authority are responsible for strictly controlling development in line with land use policies and for ensuring that all owners and users of property are aware of the risks of developing in an area that is subject to flooding. These regulations vary with each location and generally depend on the flood risk.

The ICLR flood requirements are, in general, follows the provincial and municipal guidelines and policies:

1. flood proofing means structural and/or non-structural measures incorporated in the design of a building or structure which reduce or eliminate the risk of flood damage by ensuring that the ground floor elevation is higher than the projected flood level and that the building can be exited without hindrance in the event of a flood.

2. floodway means the inner portion of a flood risk area where the risk of flood is greatest, on average once in twenty years, and where the flood depths and water velocities are greatest.
3. floodway fringe means the outer portion of a flood risk area, between the floodway and the outer boundary of the flood risk area, where the risk of flooding is lower, on average once in one hundred years, and flood waters are shallower and slower.

The flood risk areas mapped under the Flood Damage Reduction Program are generally available at local municipalities:

1. Within a floodway: new residential development is restricted to non-building uses.
2. Within a floodway fringe: new buildings and structures, provided they are floodproofed, may be permitted.

Under the *Designed... for safer living®* program, the following requirements **must** be met:

Mandatory Requirements:

1. The building must comply with all of the provisions of the provincial and municipal building regulations for construction in flood risk zones.
2. The minimum elevation of the bottom of the lowest habitable floor shall comply with local regulations. Where local regulations are not available, it shall not be the greater of:
 - a) 3 feet (1m) above the base flood elevation (BFE);
 - b) 1.2 times the flood elevation in floodway fringe zones; or,
 - c) 1-ft (0.3m) above the 500 year flood elevation (if known).
3. For BFE or flood height of 15 feet (5m) or less, the 3 feet (1m) limit would apply; otherwise the freeboard would be 1.2 times the BFE or flood height. Preference would be to use 1-ft above the 500 year flood elevation if it is known or can be determined.

Building Requirements

1. **Foundation:** The design, height and type of foundation to be used on homes built in areas within the flood fringe zones must comply with the requirements of the local planning authorities. If there are no regulations available, the following requirements shall be adhered to as minimum:
 - a) Homes in Non- flood fringe zones must be designed and constructed with the lowest habitable floor (including basements) above the Base Flood Elevation (BFE) by at least 2 ft (0.6m). Community records or a licensed survey are required to determine the BFE.
 - b) Homes in flood fringe zones must be constructed on open foundation (including elevated-enclosed with breakaway walls) with continuous piles. The bottom of the lowest horizontal support member must be above the BFE by at least 2 ft (0.6m). Verify with local building planning authorities for other allowable foundation types such as crawlspaces with flood vents.
2. **Utilities:** Electrical, heating, ventilation, plumbing, air conditioning equipment and other service facilities must be elevated above the BFE by at least 2 ft (0.6m) in flood fringe zones. Builders must verify with local planning authorities for site specific regulations with regards to utilities in flood risk areas.

9 HAIL REGION CRITERIA

Hail can be extremely dangerous and can cause extensive damage to property.

Site Requirement

Atmospheric Environment Service (AES), Environment Canada, classified Regions in Canada with the most frequent hail are the central and eastern prairies (parts of Alberta, Saskatchewan and Manitoba), south-central British Columbia and southwestern Ontario. Central and Eastern Canada generally have frequencies below 1 hail day per year. Canadian hail climatology maps are available and they are generally used to help identify vulnerable regions, and thus areas where mitigation efforts should be concentrated

Mandatory Requirements:

Install an impact resistant roof covering – UL 2218 Class 4 or FM 4473 Class 4. (Note that UL test is designed for flexible roof covering products, and the FM test is designed for rigid roof covering products). This is the only criterion for Hail regions.

1. UL 2218 is a test that is administered by Underwriters Laboratories and involves dropping steel balls of varying sizes from heights designed to simulate the energy of falling hailstones. Roofing products receiving a score of 1, referred to as Class 1, are most likely to be damaged during a hailstorm, while products receiving a Class 4 rating are expected to provide the greatest protection from hail impact. Class 4 indicates that the product was still functional after being struck twice in the same spot by 2" (50mm) steel balls. For instance, a standard wood-shake shingle, because of its susceptibility to hail damage, may receive a Class-1 UL rating, while a polymer-modified asphalt shingle or concrete tile may receive a Class 4 rating. It is therefore possible to design and construct a roof that is nearly resistant to hail damage with the right combination of a high-quality shingle product, a thin layer of underlayment and rigid decking material all installed on a well-pitched roof.

Examine the package of the roof cover product, or consult manufacturer documentation to determine if the product has met the Class 4 designation of UL 2218. If difficulty is encountered locating products that meet UL 2218 Class 4, contact the **Designed ... for safer living®** program manager at ILRC for a list of approved roof covering products. Note that this standard is appropriate for flexible roofing products like asphalt shingles, and metal panels or shingles.

2. FM 4473 is administered by Factory Mutual Research and is a test that is similar to UL 2218, but instead of using steel balls, frozen ice balls are used. The FM 4473 test standard is used on rigid roof covering materials (like cement tiles) and involves firing the ice balls from a sling or air cannon at the roof-covering product. Class 4 indicates that the product was still functional after being struck twice in the same spot by a 2" (25mm) ice ball.

10 OTHER PERILS

INTERNAL FIRE CRITERIA

Designed ... for safer living® criteria have been developed for mitigation of damage caused by fire inside the home. For evident reasons, a fire inside the home is considered a severe hazard to both life and property. As a minimum, *Designed ... for safer living*® homes shall meet the minimum requirements of the NBCC Par 9, Housing and Small Buildings.

With the above in mind, the following requirements are either **mandatory or recommended**, as indicated:

Mandatory

1. Smoke alarms conforming to CAN ULC –S531, `Smoke Alarms`` shall be installed in each dwelling unit and in each sleeping room not within a dwelling unit.
2. Smoke alarms shall be installed by permanent connections to an electrical circuit and shall have no disconnect switch.
3. Install arc fault circuit interrupters on circuits that are supplying power to sleeping facility of a dwelling unit as per requirement of Canadian Electrical Code.
4. Install smooth sheet metal dryer vent pipe assembled with pop-rivets (no screws) and in a length no greater than 15-feet (5m) to the exterior. Not allowed to discharge into the attic space or garage.
5. Provide a full fire separation wall between an attached garage and living spaces as required by NBCC. Provide an 1-hour rated ceiling in any attached garage.
6. Solid or 1-hour fire-rated door between attached garage and house.

Recommended

1. Homes shall be equipped with a sprinkler system that meets NFPA 13D for residential applications.
2. Use only screw-wired connection electrical outlets. Back-wired connection electrical outlets are not allowed.

BURGLARY CRITERIA

Designed ... for safer living® criteria have been developed for mitigation of damage and/or losses caused by burglary. The goal is to deter/prevent burglars entering the home, and protect occupants and/or valuables inside the home.

With the above in mind, the following requirements are **strongly recommended**:

1. Install solid core doors at exterior locations and from an attached garage into the living space. Doors shall be a minimum 1 ¾" (45mm) thick. Steel doors shall be a minimum 24 gauge. Provide an escutcheon plate around the door edge (for any door with a wood edge) at the dead bolt lock. Steel edged doors do not need an escutcheon plate.
2. Install ANSI Grade 1 deadbolt locks with a minimum 1" (25mm) long throw at all doors at exterior locations and from an attached garage into the living space. Reinforce any wood door frame for these doors with a metal (steel or aluminum) reinforcing plate at each deadbolt lock strike plate. The strike plate shall be a high security strike plate attached with a minimum four (4) 3" (75mm) long screws to the reinforcing plate. The reinforcing plate shall extend at least 12" (300mm) on either side of the deadbolt lock location and be attached with a minimum eight (8) 3" (75mm) long screws to the house wall framing.
3. At exterior doors and doors from attached garage to living spaces, install hardwood shims at all hinge locations and install hinges with 3" (75mm) long screws.
4. At all exterior doors and doors from an attached garage to a living space, for framed wall construction, reinforce the walls on both door jambs with horizontal framing members in the three stud spaces next to the door opening.
5. Install windows that meet CAN CSA –A440 and ASTM F 588-97.
6. Security System:
 - a. Option 1: Pre-wire home for security system that will provide contacts at all windows and doors plus motion and glass break detectors.
 - b. Option 2: Install a security alarm system with contacts at all windows, exterior doors, doors between garage and living space, and on the garage door. Install glass break detectors for all windows. Install a strobe/audible alarm on the exterior of the house facing the street or more visible location and in a place that cannot be easily accessed from the ground. Where allowed by law, install security cameras that can be accessed remotely to visibly verify the alarm.
7. Install an in-concrete-floor, in-concrete -or masonry-wall safe.
8. Install at least two motion sensing exterior lights on each side of the house or no greater than 30' (10m) apart around the house in locations that are not easily accessible from the ground without a 6' (1.8m) step ladder.

ELECTRICAL SURGE CRITERIA

- .1 Provide a service-entrance (whole-house) surge protector with protection for electrical, telephone, and cable or satellite TV lines entering the house. Provide surge suppression in accordance to ANSI/IEEE C62.41. All transient voltage surge suppressors (TVSS) shall be listed under UL 1449 and certified by CSA. A nameplate showing the electrical rating including UL 1449 Surge Suppression ratings and the UL and CSA monograms shall be permanently affixed to the unit. The TVSS shall be MOV based with surges being distributed equally to all MOV components. The Maximum Continuous Operating Voltage (MCOV) shall be greater than 115% of the nominal system voltage. The TVSS shall be four mode and capable of sustaining a surge of 150ka line to neutral. The protector is to be installed in accordance with Section 26-250 of the Canadian Electrical Code. The service entrance surge protector shall have a working indicator light.
- .2 The home's electrical system shall be properly grounded in accordance with Section 10 – Grounding and Bonding - of the Canadian Electrical Code. It is important that all utilities (telephone, electrical, and cable or satellite TV) be bonded to the same grounding point, for proper operation of the surge protection system and to prevent ground potentials developing on the electrical system. All utilities (telephone, electrical, and cable or satellite TV lines) shall enter the house within 10-feet of electrical service entrance ground wire.

ARMoured LAUNDRY HOSES

- .1 Install armoured laundry hoses.

BACKUP GENERATOR

- .1 Provide a backup generator size and model to be determined.
- .2 Wire emergency generator to manual transfer switch as required by the Canadian Electrical Code. Size and model of transfer switch to be determined.
- .3 Generator and transfer switch to be installed in accordance with Section 28 of the Canadian Electrical Code.

11 REFERENCES

Canadian

1. National Building Code of Canada (NBCC).
2. Canadian Electrical Code.
3. Canadian Plumbing Code.
4. Canadian Hurricane Centre.
5. Wood Design Manual (CSA).
6. CSA 086.1 Engineering Design in Wood.
7. CSA A23.3 Design of Concrete Structures.
8. CSA S304.1 Masonry Design for Buildings.
9. Flood Risk Maps for Areas, Villages and River Systems in Atlantic Canada, Environment Canada
10. An Assessment of Flood Risk Management in Canada; 2003, ICLR.
11. CSA A123.22-08 "Standard Specification for Self-Adhering Polymer Modified Bituminous Sheet Materials Used as Steep Roofing Underlayment for Ice Dam Protection."
12. CSA A123.03-05 "Asphalt Saturated Organic Roofing Felt".
13. CSA 101/I.S or ASTM E 2112-01 – Standard Practice for Installation of Exterior Windows, Doors, and Skylights
14. Canada's Hail Climatology: 1977 – 1993; David Etkin & Soren Erik Brun; 2001.

USA

1. AAMA 1402-86 "Standard Specifications for Aluminum Siding Soffit and Fascia" American Architectural Manufacturers Association. www.aamanet.org . 2003.
2. ANSI/AAMA/NWWDA 101/1.S.2-97. American National Standard. Voluntary Specifications for Aluminum, Vinyl (PVC) and Wood Windows and Glass Doors. American Architectural Manufacturers Association, Schaumburg, IL, 1997
3. ASCE 7-98: Minimum Design Loads for Buildings and Other Structures. American Society of Civil Engineers. Reston, Virginia, 2000.
4. ASTM D3161-03b "Standard Test Method for Wind-Resistance of Asphalt Shingles" ASTM International, West Conshohocken, PA, 2001.
5. ASTM D1970-01. "Standard Specification for Self-Adhering Polymer Modified Bituminous Sheet Materials Used as Steep Roofing Underlayment for Ice Dam Protection." ASTM International, West Conshohocken, PA, 2001.
6. ASTM E136 "Standard Test Method for Behavior of Materials in a Vertical Tube Furnace at 750°C (1382°F)," ASTM International, West Conshohocken, PA.
7. ASTM E1592 "Standard Test Method for Structural Performance of Sheet Metal Roof and Siding Systems by Uniform Static Air Pressure Difference" ASTM International, West Conshohocken, PA
8. ASTM E2112-01 "Standard Practice for Installation of Exterior Windows, Doors, and Skylights" ASTM International, West Conshohocken, PA, 2001.
9. ASTM D6381 "Standard Test Method for Measurement of Asphalt Shingle Mechanical Uplift Resistance" ASTM International, West Conshohocken, PA.
10. Coastal Construction Manual, 3rd edition, FEMA 55. Federal Emergency Management Agency, Mitigation Directorate, June 2000
11. FM 4473: Specification Test Protocol for Impact Resistance testing of Rigid Roofing Materials by Impacting with Freezer Ice Balls. Class 4473. September 1999. Factory Mutual Research.
12. HIP-91 Commentary and Recommendations for Handling, Installing and Bracing Metal Plate Connected Wood Trusses, Truss Plate Institute, Inc., Madison, WI, 1991.
13. "Installation Masters Training Manual," American Architectural Manufacturers Association, Schaumburg, IL, 2000.
14. "Is your home protected from hail damage? A homeowner's guide to roofing and hail." The Institute for Business and Home Safety. Tampa, FL 1999.
15. "Is your home protected from hurricane disaster? A homeowner's guide to hurricane retrofit." The

- Institute for Business and Home Safety. Tampa, FL 1998.
16. "Is your home protected from wildfire disaster? A homeowner's guide to wildfire retrofit." The Institute for Business and Home Safety. Tampa, FL 2001.
 17. Low Slope Roofing Material Guide, 1999, National Roofing Contractors Association, Rosemont, IL, 1999.
 18. NER-272: Power-Driven Staples and Nails for use in all types of Building Construction. National Evaluation Service, Inc. September 1997.
 19. SSTD10-99 "Southern Standards Technical Document 10 - Standard for Hurricane Resistant Residential Construction." Southern Building Code Congress International, Birmingham, AL 1999.
 20. Steep Slope Roofing Material Guide, 1999, National Roofing Contractors Association, Rosemont, IL, 1999.
 21. UL 2218 "Impact Resistance of Prepared Roof Covering Materials," Underwriters Laboratories Inc., Northbrook, Illinois, 1996. ISBN 0-7629-0033-4
 22. UL 2390 "Test Method for Wind Resistant Asphalt Shingles with Sealed Tabs" Underwriters Laboratories Inc., Northbrook, Illinois, 1996. ISBN 0-7629-0033-4
 23. *Designed... for Safer Living* – Disaster Resilient Homes; Home Builder's Guide 2007.

12 CONTACT INFORMATION

Institute for Catastrophic Loss Reduction (ICLR)
Richmond Street East, Suite 210
Toronto, Ontario,
M5C 2R9
Tel: 416-364-8677
Website: www.ICLR.org

Tracy Waddington, Program Director
Designed ... for safer living®
Tel: 416-364-8677
Fax: 416-364-5889
Email: twaddington@ICLR.org

APPENDIX 'A'
SEISMIC HAZARD ZONES

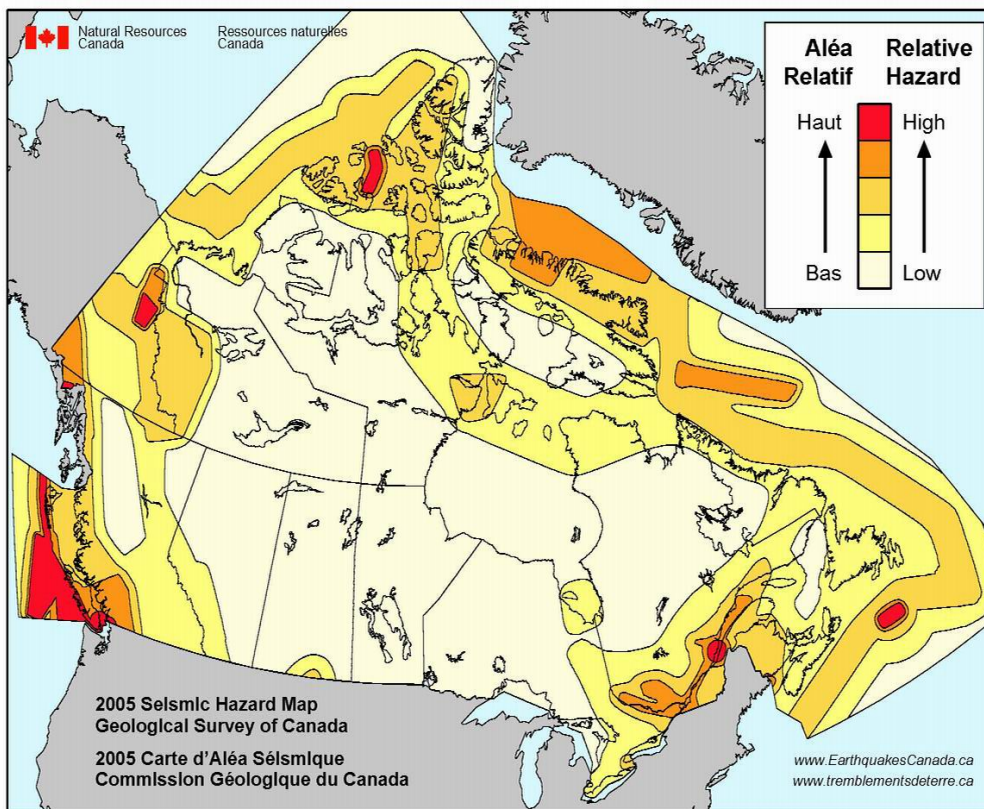

Canada

Figure 8.1: Map showing active seismic hazard zones in Canada (Natural Resources Canada) *Seismic Force Resisting System (SFRS)*

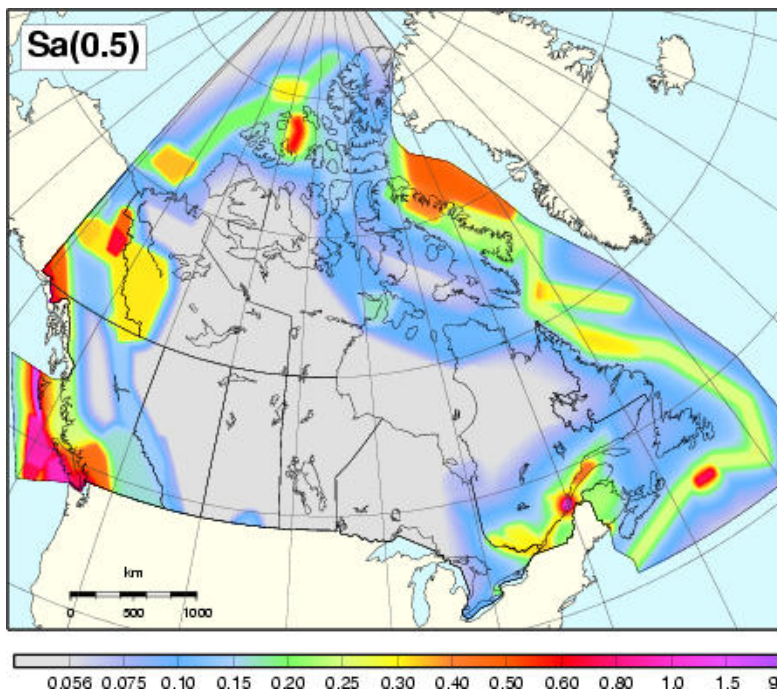

Figure 16-2 Spectral Acceleration for a period of 0.5 seconds at a probability of 2%/50 years for firm ground conditions (NBCC soil class C), Natural Resources Canada, 2005 NBCC Seismic Hazard Maps, 10 Feb. 09)

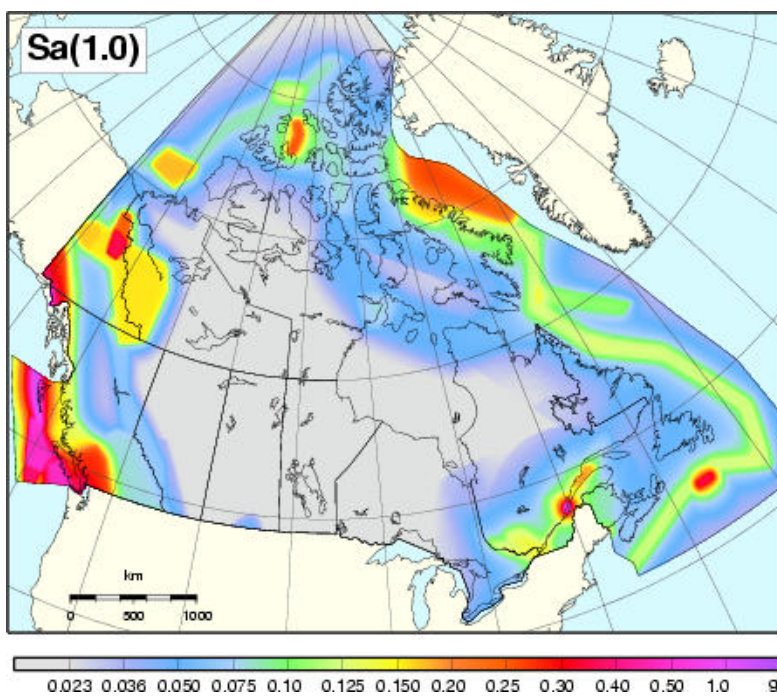

Figure 16-2 Spectral Acceleration for a period of 1.0 seconds at a probability of 2%/50 years for firm ground conditions (NBCC soil class C), Natural Resources Canada, 2005 NBCC Seismic Hazard Maps, 10 Feb. 09)

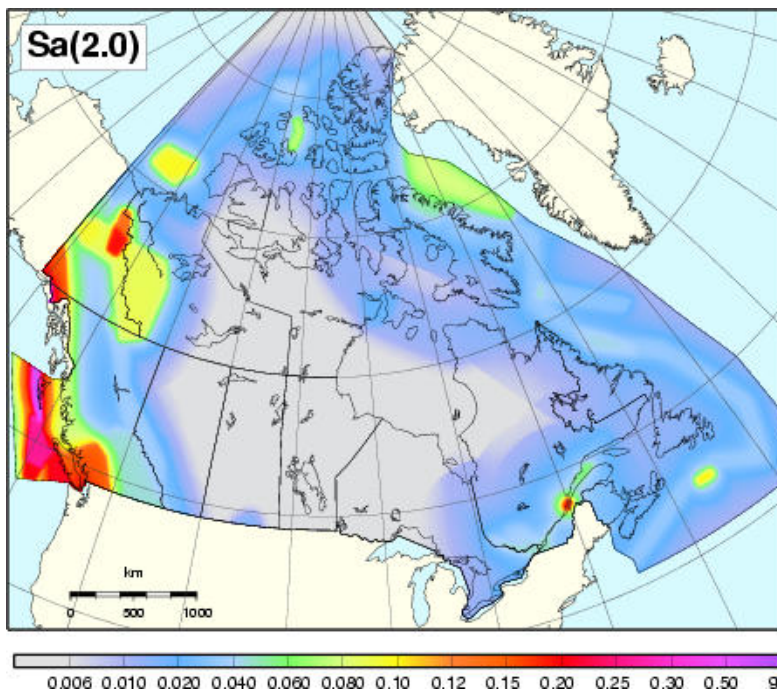

Figure 16-2 Spectral Acceleration for a period of 2.0 seconds at a probability of 2%/50 years for firm ground conditions (NBCC soil class C), Natural Resources Canada, 2005 NBCC Seismic Hazard Maps, 10 Feb. 09)

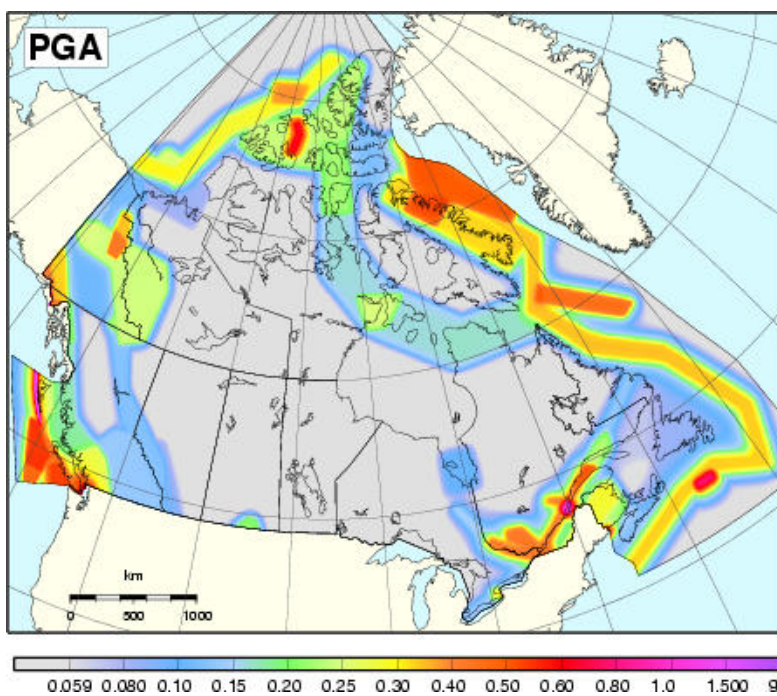

Figure 16-2 Peak Ground Acceleration at a probability of 2%/50 years for firm ground conditions (NBCC soil class C), Natural Resources Canada, 2005 NBCC Seismic Hazard Maps, 10 Feb. 09)

APPENDIX 'B'
FOUNDATION REINFORCING FOR SEISMIC

Foundation Reinforcement Requirements for Seismic Regions

This appendix contains seven illustrations, each of a different commonly used foundation system. The drawings and text contained therein show the minimum reinforcement requirements for foundations of **Designed ... for safer living®** homes built in areas defined by the **Designed ... for safer living®** program as seismic risk zones. Note that each illustration is preceded by a title that describes what type of system it is. An elevation (left) and a profile (right) are shown for each system. It should also be noted that some regions the building planning authorities require the design to be reviewed and approved by a registered professional engineer to ensure that the design complies with national and local standards and regulations.

Concrete frost wall supporting wood framed construction

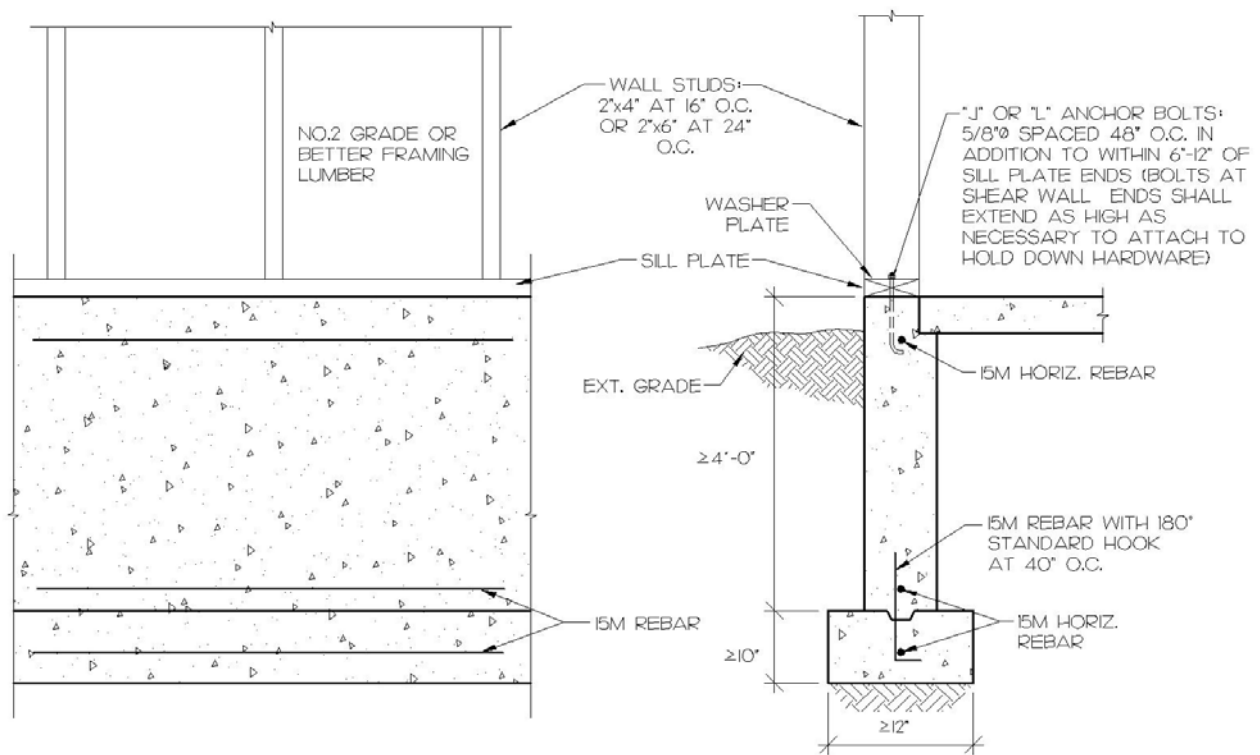

Slab-on-ground with monolithic turned-down footing; supporting wood-frame construction

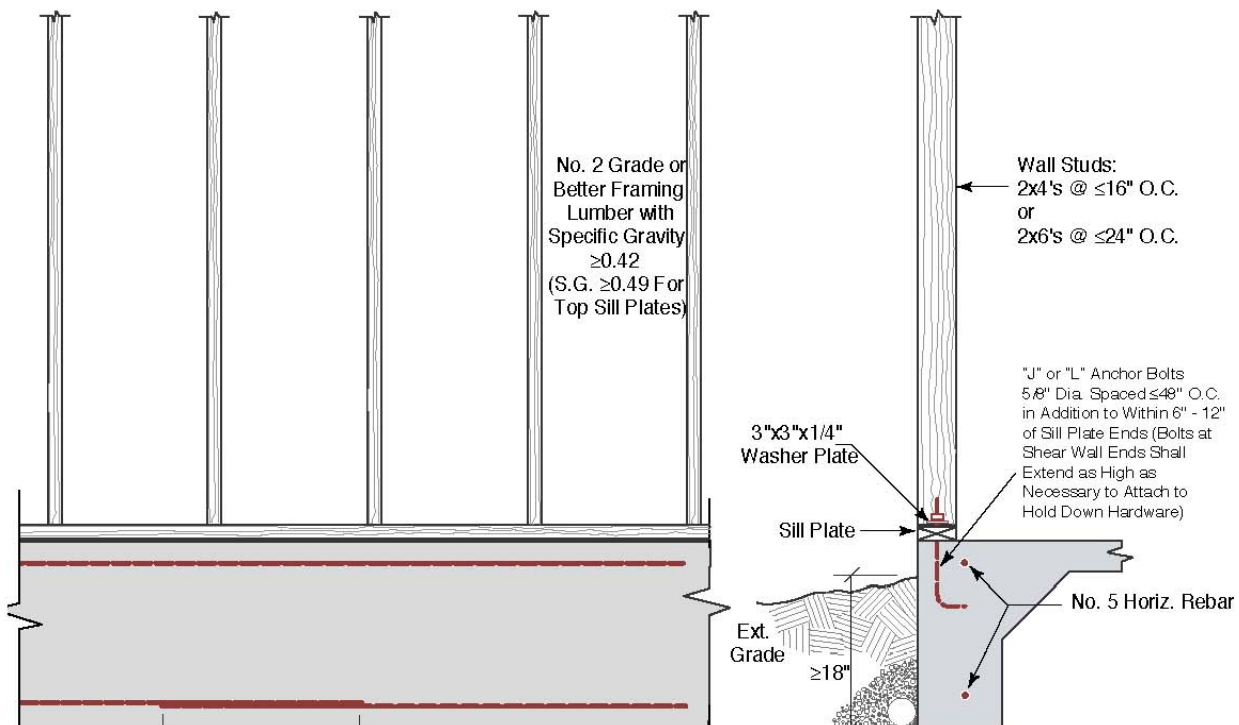

Concrete basement wall supporting wood framed construction

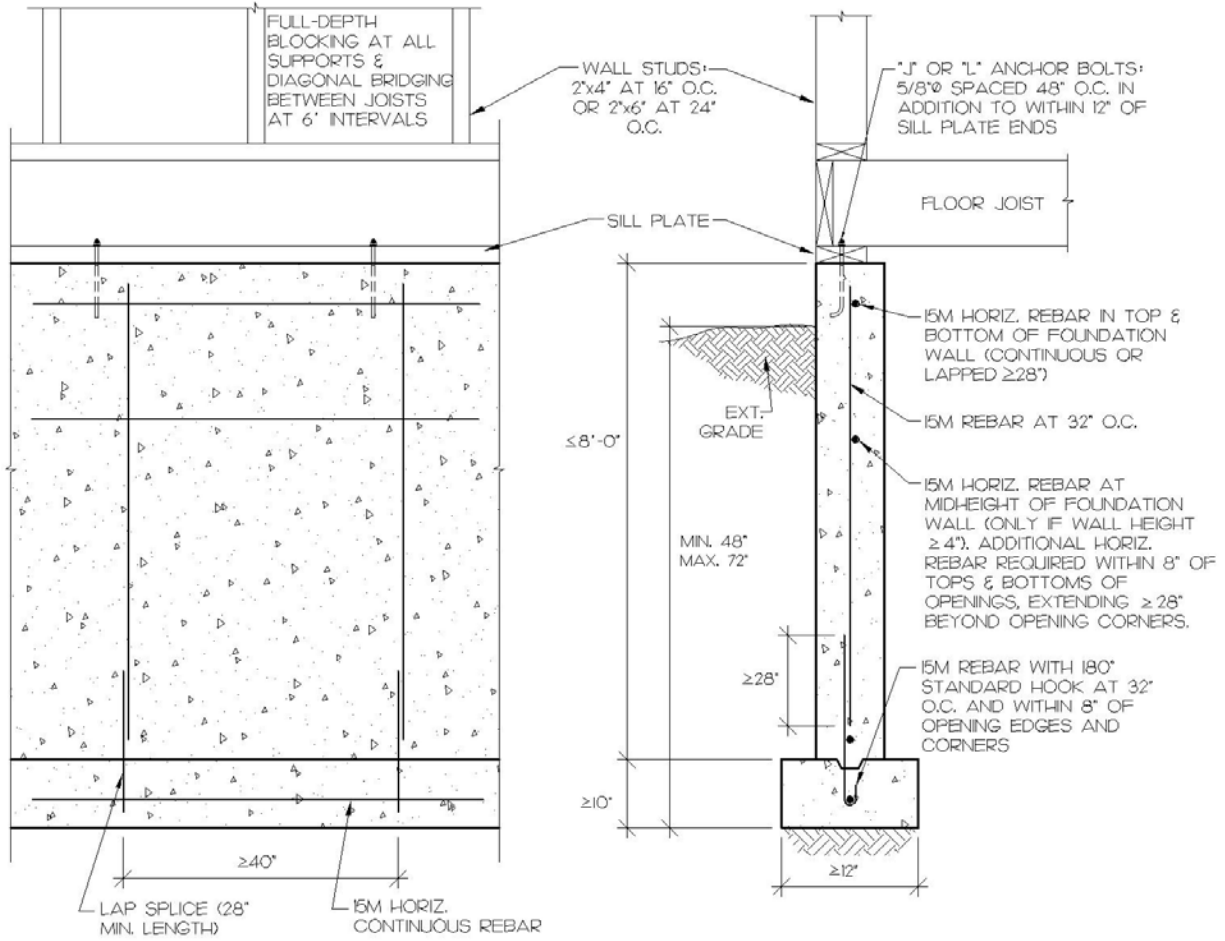

Strip footing and concrete block foundation wall; supporting concrete block walls

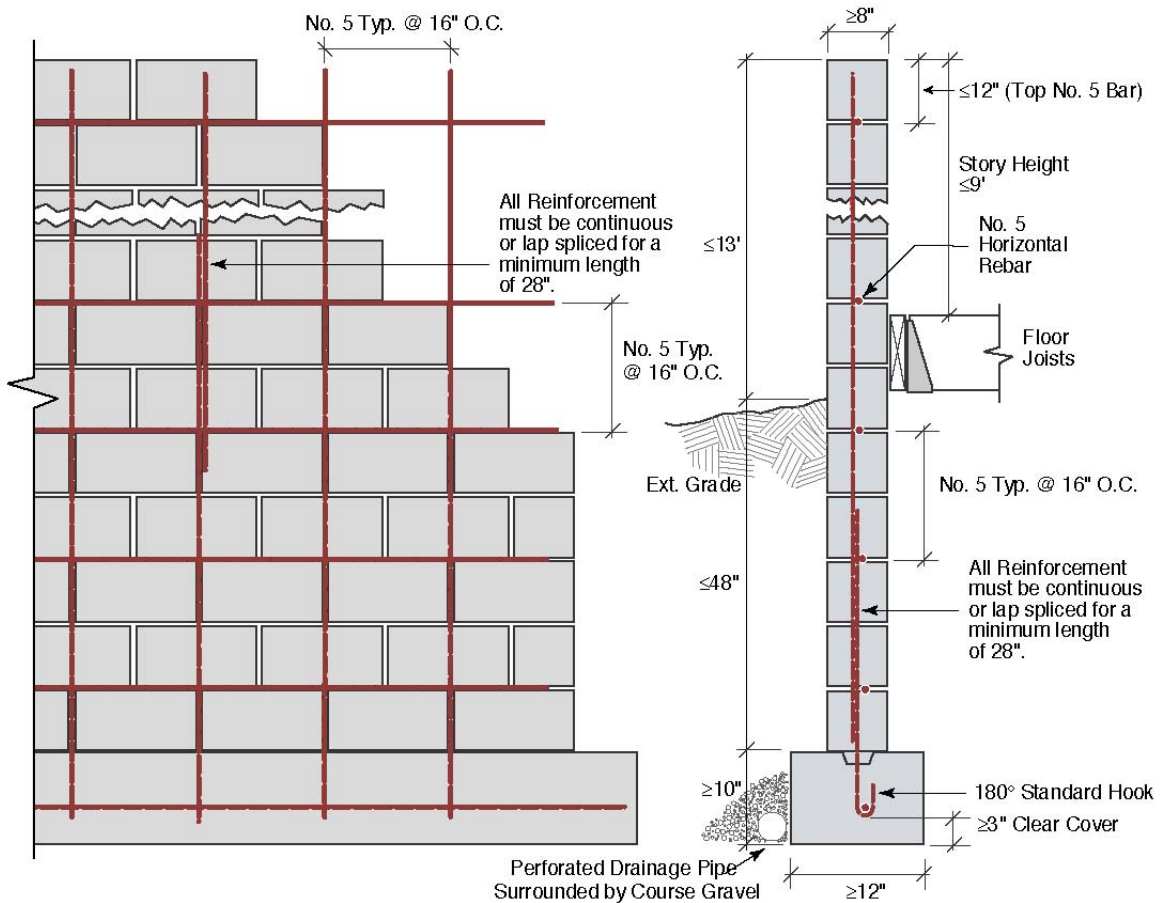

Slab-on-ground with monolithic turned-down footing; supporting concrete block walls

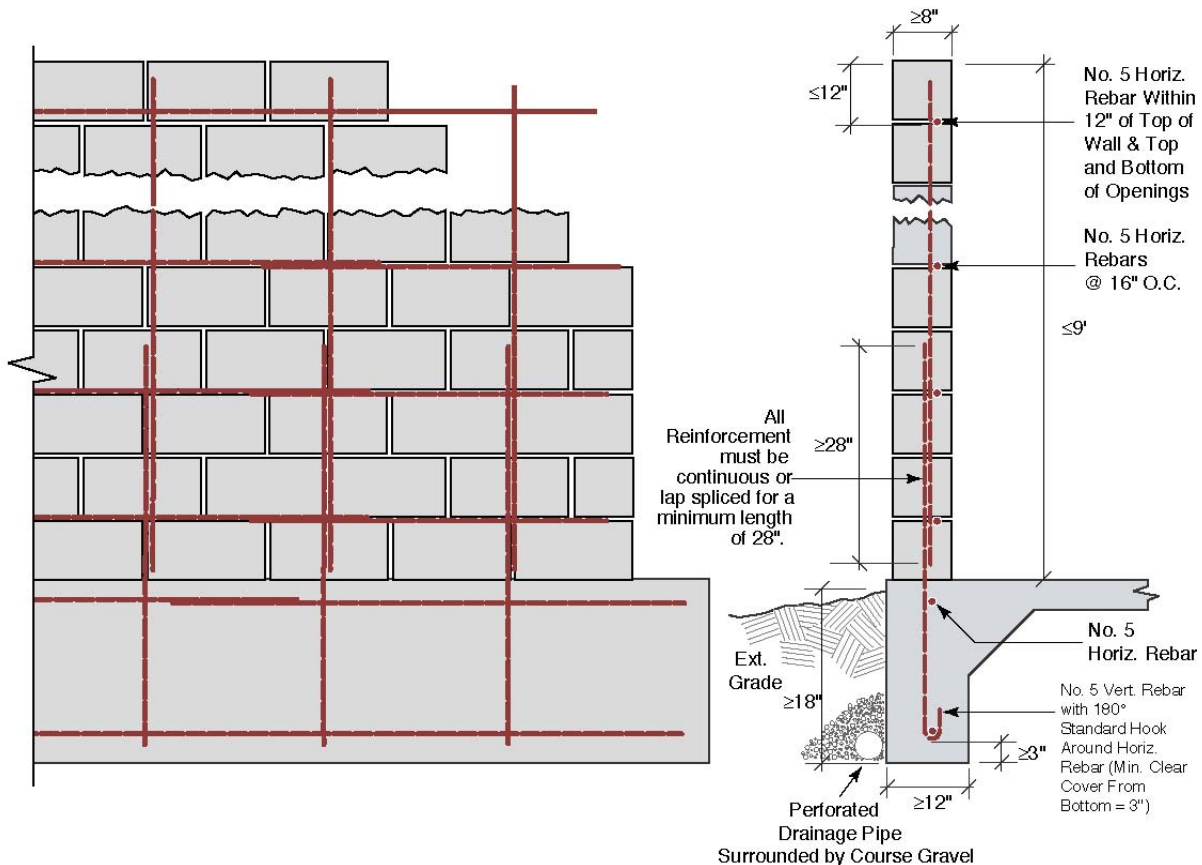

Strip footing and concrete block foundation wall; supporting wood-frame construction

